



HEYGO TOOLS

— NO WORDS JUST TRY —

Cutting Tools Catalogue



FOCUS INNOVATION

ABOUT HEYGO

Heygo Tools is specialized in the production of machine taps, HSS drills, and other cutting tools since 1959.

The journey started 60 years ago and it still continues. You must have listened to the proverb: "The old is gold": We are the speaking proof of it as many ages experience and maturity of Heygo Tools make it offer professional tools with stronger stability.

Focus, Innovation, Research and Development: Everyone of Heygo Team is devoted to make heygo a world-class cutting tools manufacturer, increase your processing efficiency, reduce your cost of each hole by supplying you quality tools and service.

Heygo team would be pleased to advise you - Test us and see for yourself!



HSS DRILLS

STRAIGHT SHANK TWIST DRILL

Code	Product Name	Page
SD	Straight Shank Twist Drill DIN338	06
SDS	Straight Shank Short Twist Drill DIN1897	09
LSD	Straight Shank Long Twist Drill DIN340	11
ELSD	Straight Shank Extra-long Twist Drill	13
PELSD	Parabolic Flute Straight Shank Extra-long Twist Drill for Deep Hole	14
COSD	Straight Shank Twist Drill for Stainless Steel DIN338	15
COLSD	Straight Shank Long Twsit Drill for Stainless Steel DIN340	17
JSD	Jobber Length Straights Shank Twist Drills ANSI B94.11M	19
TSD	Taper Length Straights Shank Twist Drills ANSI B94.11M	20
SSD	Screw Length Straights Shank Twist Drills ANSI B94.11M	21



TAPER SHANK TWIST DRILL

Code	Product Name	Page
TD	Taper Shank Twist Drill	22
LTD	Taper Shank Long Twist Drill	25
ELTD	Taper Shank Extra-Long Twist Drill	27
PELTD	Parabolic Flute Taper Shank Twist Drill for Deep Hole	31
COTD	Taper Shank Twist Drill for Stainless Steel	35
COLTD	Taper Shank Long Twist Drill for Stainless Steel	37





OTHER DRILLS		
Code	Product Name	Page
NOS	Noss Drill	39
ACDT	A Type Center Drill with TiN Coating	40
BCDT	B Type Center Drill with TiN Coating	40
BSCDT	BS Type Center Drill with TiN Coating	41
COSPDT	Spot Drill with TiN Coating	41

TAPS



Code	Product Name	Page
ISHTB	Straight Flute Tap ISO529 for Blind Hole	43
ISHTT	Straight Flute Tap ISO529 for Through Hole	45
DIN352HT	Hand Tap Set	47
DIN2181HT	Hand Tap Set	49
ISSFT	Spiral Flute Machine Tap ISO 529	51
ALSFT	Spiral Flute Machine Tap for Aluminum	53
CDT	Combination Drill Tap	54
CDTANSI	Combination Drill Tap ANSI	55
ISSPPT	Spiral Point Tap ISO 529	56
JISSFT	Spiral Flute Machine Tap JIS	58
JISSPPT	Spiral Point Tap JIS	60
DIN371SFT	Spiral Flute Tap DIN 371	62

TAPS

Code	Product Name	Page
DIN376SFT	Spiral Flute Tap DIN 376	63
DIN374SFT	Spiral Flute Tap DIN 374	64
DIN371SPPT	Spiral Point Tap DIN 371	66
DIN376SPPT	Spiral Point Tap DIN 376	67
DIN374SPPT	Spiral Point Tap DIN374	68
PT	55°(ZG) Taper Pipe Tap PT	70
NPT	60°(Z) Taper Pipe Tap NPT	70
G	55°(G) Cylindrical Pipe Tap	71
UN	UNC/UNF Tap	72



CNC TOOL

CARBIDE DRILL		
Code	Product Name	Page
3CD	3xD Solid Carbide Twist Drill	75
5CD	5xD Solid Carbide Twist Drill	77
3CDSS	3xD Solid Carbide Twist Drill for stainless steel	79
5CDSS	5xD Solid Carbide Twist Drill for stainless steel	81
3HCD	3xD High Hardness Carbide Twist Drill	83
5HCD	5xD High Hardness Carbide Twist Drill	85
3CDA	3xD Solid Carbide Twist Drill for Aluminum	87
5CDA	5xD Solid Carbide Twist Drill for Aluminum	89





INDEXABLE DRILL

Code	Product Name	Page
2DWC	2xD WC Type Indexable Drill	91
2DSP	2xD SP Type Indexable Drill	92
3DWC	3xD WC Type Indexable Drill	93
3DSP	3xD SP Type Indexable Drill	94
4DWC	4xD WC Type Indexable Drill	95
4DSP	4xD SP Type Indexable Drill	96
5DWC	5xD WC Type Indexable Drill	97
5DSP	5xD SP Type Indexable Drill	98
WCMX	WC Type Carbide Insert	99



CARBIDE ENDMILL

Code	Product Name	Page
2CE	Solid Carbide 2 Flutes Endmill	100
4CE	Solid Carbide 4 Flutes Endmill	101
3CEA	Solid Carbide 3 Flutes Endmill for Aluminum	102
4CESS	Solid Carbide 4 Flutes Endmill for Stainless Steel	103
H2CE	High Hardness Solid Carbide 2 Flutes Endmill	104
H4CE	High Hardness Solid Carbide 4 Flutes Endmill	105

HSS DRILLS

60 YEARS FOCUS INNOVATION

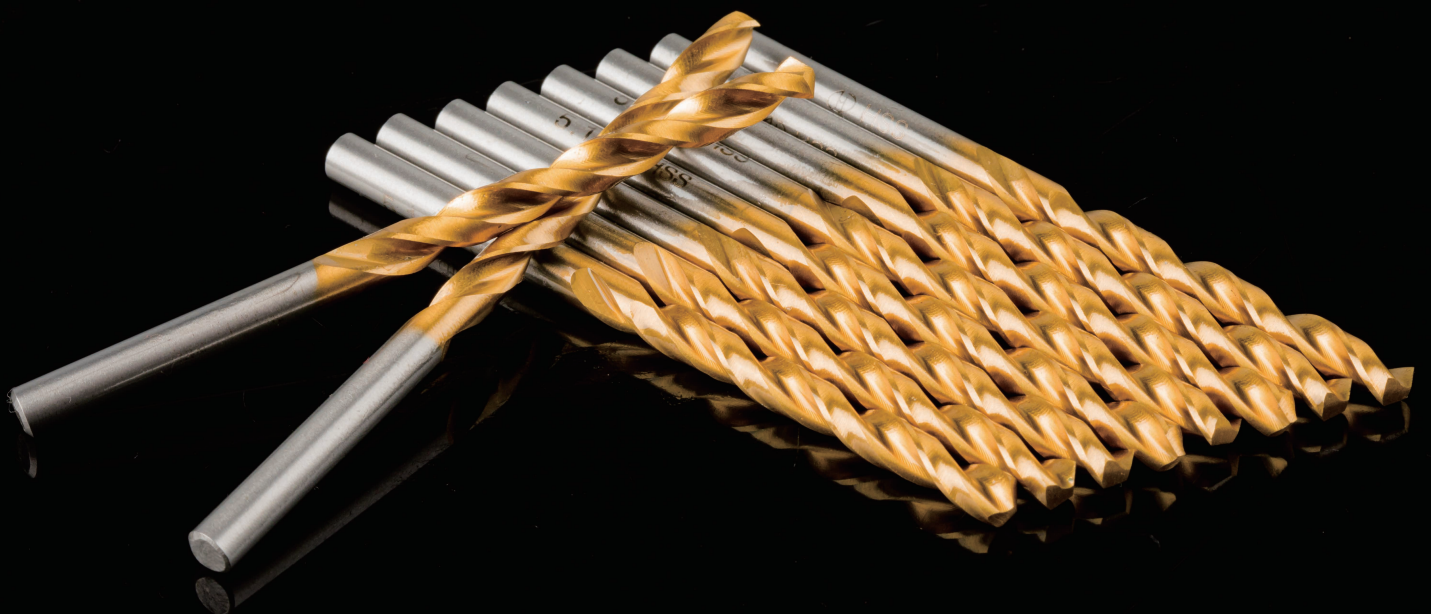

SD

Straight Shank Twist Drill DIN338



Material



Tolerance



Point Angle



Helix Angle

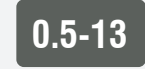

Diameter Range

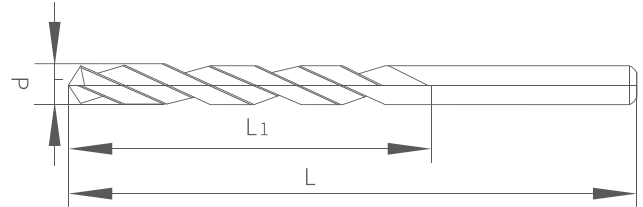

How to Order: SD+ Size / SD+ TiN+ Size

Unit: mm

Size:d (h8)	L	L1
0.50	30	10
0.82		
0.85		
0.88		
0.90		
0.92	32	11
0.95		
0.98		
1.00		
1.05		
1.10	36	14
1.15		
1.20		
1.25		
1.30		
1.35	40	18
1.40		
1.45		
1.50		
1.55		
1.60	43	20
1.65		
1.70		
1.75		
1.80		
1.85	46	22
1.90		
1.95		
2.00		
2.10		
2.15	53	27
2.20		
2.25		
2.30		
2.35		

Size:d (h8)	L	L1
2.40	57	30
2.45		
2.50		
2.55		
2.60		
2.65	61	33
2.70		
2.75		
2.80		
2.85		
2.90	65	36
2.95		
3.0		
3.1		
3.2		
3.3	70	39
3.4		
3.5		
3.6		
3.7		
3.8	75	43
3.9		
4.0		
4.1		
4.2		
4.3	80	47
4.4		
4.5		
4.6		
4.7		
4.8	86	52
4.9		
5.0		
5.1		
5.2		

Size:d (h8)	L	L1
5.3	86	52
5.4	93	57
5.5		
5.6		
5.7		
5.8		
5.9		
6.0	101	63
6.1		
6.2		
6.3		
6.4		
6.5		
6.6		
6.7	109	69
6.8		
6.9		
7.0		
7.1		
7.2		
7.3		
7.4		
7.5	117	75
7.6		
7.7		
7.8		
7.9		
8.0		
8.1		
8.2		
8.3		
8.4		
8.5	125	81
8.6		
8.7		
8.8		
8.9	125	81
9.0		
9.1		
9.2		
9.3	133	87
9.4		
9.5		
9.6		
9.7		

Size:d (h8)	L	L1
9.8	133	87
9.9		
10.0		
10.1		
10.2		
10.3		
10.4		
10.5	142	94
10.6		
10.7		
10.8		
10.9		
11.0		
11.1		
11.2		
11.3	151	101
11.4		
11.5		
11.6		
11.7		
11.8		
11.9		
12.0		
12.1		
12.2		
12.3	160	108
12.4		
12.5		
12.6		
12.7	169	114
12.8		
12.9		
13.0		
13.1	169	114
13.2		
13.3		
13.4		
13.5	169	114
13.6		
13.7		
13.8		
13.9	169	114
14.0		
14.1-14.4		
14.5		

Size:d (h8)	L	L1
14.6-14.9	169	114
15.0		
15.1-15.4	178	120
15.5		
15.6-15.9		
16.0		
16.1-16.5	184	125

Size:d (h8)	L	L1
16.6-17.0	184	125
17.1-17.5	191	130
17.6-18.0		
18.1-18.5	198	135
18.6-19.0		
19.1-19.5	205	140
19.6-20.0		

SDS

Straight Shank Twist Drill DIN1897



Material



Tolerance



Point Angle



Helix Angle

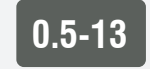

Diameter Range

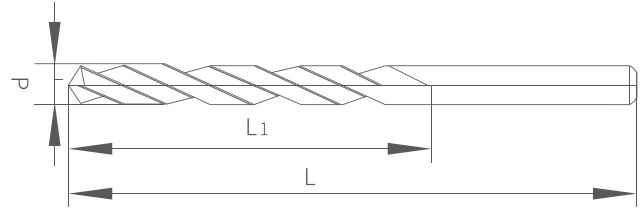

How to Order: SDS+ Size / SDS+ TiN+ Size

Unit: mm

Size:d (h8)	L	L1
1.0	26	6
1.1	28	7
1.2	30	8
1.3		
1.4	32	9
1.5		
1.6	34	10
1.7		
1.8	36	11
1.9		
2	38	12
2.1		
2.2	40	13
2.3		
2.4	43	14
2.5		
2.6	46	16
2.7		
2.8	49	18
2.9		
3	52	20
3.1		
3.2	55	22
3.3		
3.4	58	24
3.5		
3.6	52	20
3.7		
3.8	55	22
3.9		
4	58	24
4.1		
4.2	58	24
4.3		
4.4		

Size:d (h8)	L	L1
4.5	58	24
4.6		
4.7	62	26
4.8		
4.9	66	28
5		
5.1	70	31
5.2		
5.3	74	34
5.4		
5.5	79	37
5.6		
5.7	79	37
5.8		
5.9	79	37
6		
6.1	79	37
6.2		
6.3	79	37
6.4		
6.5	79	37
6.6		
6.7	79	37
6.8		
6.9	79	37
7		
7.1	79	37
7.2		
7.3	79	37
7.4		
7.5	79	37
7.6		
7.7	79	37
7.8		
7.9		

Size:d (h8)	L	L1
8	79	37
8.1		
8.2		
8.3		
8.4		
8.5		
8.6	84	40
8.7		
8.8		
8.9		
9		
9.1		
9.2		
9.3		
9.4		
9.5		
9.6	89	43
9.7		
9.8		
9.9		
10		
10.1		
10.2		
10.3		
10.4		
10.5		
10.6		
10.7	95	47
10.8		
10.9		
11		
11.1		
11.2		
11.3		
11.4		
11.5		
11.6		
11.7		
11.8		
11.9	102	51
12		
12.1		
12.2		

Size:d (h8)	L	L1
12.3	102	51
12.4		
12.5		
12.6		
12.7		
12.8		
12.9		
13		
13.1		
13.2		
13.3	107	54
13.4		
13.5		
13.6		
13.7		
13.8		
13.9		
14		
14.25	111	56
14.5		
14.75		
15		
15.25	115	58
15.5		
15.75		
16		
16.25	119	60
16.5		
16.75		
17		
17.25	123	62
17.5		
17.75		
18		
18.25	127	64
18.5		
18.75		
19		
19.25	131	66
19.5		
19.75		
20		

LSD

Straight Shank Long Twist Drill DIN340



Material



Tolerance



Point Angle



Helix Angle



Diameter Range

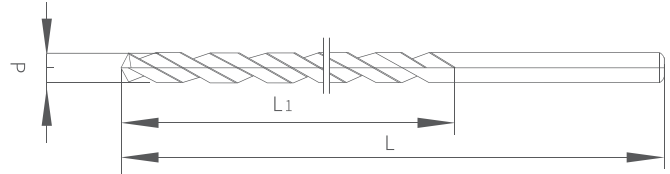

How to Order: LSD + Size/ LSD + TiN + Size

Unit: mm

Size:d (h8)	L	L1
1.5	70	45
1.6	76	50
1.7		
1.8	80	53
1.9		
2.0	85	56
2.1		
2.2	90	59
2.3		
2.4	95	62
2.5		
2.6	100	66
2.7		
2.8	106	69
2.9		
3.0	112	73
3.1		
3.2	119	78
3.3		
3.4	126	82
3.5		
3.6	132	87
3.7		
3.8	132	87
3.9		
4.0	132	87
4.1		
4.2	132	87
4.3		
4.4	132	87
4.5		
4.6	132	87
4.7		
4.8	132	87
4.9		

Size:d (h8)	L	L1
5.0	132	87
5.1		
5.2		
5.3		
5.4	139	91
5.5		
5.6		
5.7		
5.8	148	97
5.9		
6.0		
6.1		
6.2	156	102
6.3		
6.4		
6.5		
6.6	165	109
6.7		
6.8		
6.9		
7.0	165	109
7.1		
7.2		
7.3		
7.4	165	109
7.5		
7.6		
7.7		
7.8	165	109
7.9		
8.0		
8.1		
8.2	165	109
8.3		
8.4		

Size:d (h8)	L	L1
8.5	165	109
8.6	175	115
8.7		
8.8		
8.9		
9.0		
9.1		
9.2		
9.3	184	121
9.4		
9.5		
9.6		
9.7		
9.8		
9.9		
10.0	195	128
10.1		
10.2		
10.3		
10.4		
10.5		
10.6		
10.7	205	134
10.8		
10.9		
11.0		
11.1		
11.2		
11.3		
11.4	205	134
11.5		
11.6		
11.7		
11.8		
11.9		
12.0		
12.1		
12.2		
12.3		
12.4		
12.5		
12.6		
12.7		

Size:d (h8)	L	L1
12.8	205	134
12.9		
13.0		
13.1		
13.2		
13.3	214	140
13.4		
13.5		
13.6		
13.7		
13.8		
13.9		
14.0		

ELSD

Straight Shank Extra-long Twist Drill



Material



Tolerance



Point Angle



Helix Angle

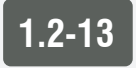

Diameter Range

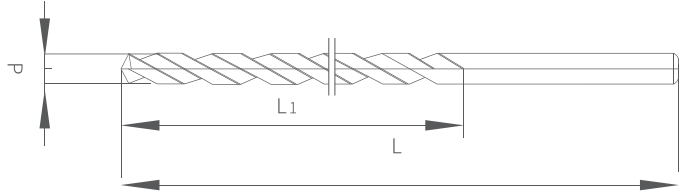

Unit: mm

How to Order: ELSD + Size

规格d (h8)	L	L1
1.2-2.3	100	50
	150	75
	160	100
	200	100
2.4-4	150	75
	160	100
	200	150
	250	125
	250	200
	300	150
4.1-5	160	100
	200	150
	250	200
	300	240
	350	285
	400	300
5.1-6	160	100
	200	150
	250	200
	300	240
	350	285
	400	300
6.1-7	160	100
	200	150
	250	200
	300	240
	350	285
	400	300
7.1-8	160	100
	200	150

规格d (h8)	L	L1
7.1-8	250	200
	300	240
	350	285
	400	300
	450	350
8.1-9	160	100
	200	150
	250	200
	300	240
	350	285
	400	300
9.1-10	160	100
	200	150
	250	200
	300	240
	350	285
	400	300
10.1-11	160	100
	200	150
	250	200
	300	240
	350	285
	400	300
11.1-12	250	200
	300	240
	350	285
	400	300
	450	350
12.1-13	250	200
	300	240
	350	285
	400	300

PELSD

Parabolic Flute Straight Shank Extra-long Twist Drill for Deep Hole



Material



Tolerance



Point Angle



Helix Angle

1.2-13

Diameter Range

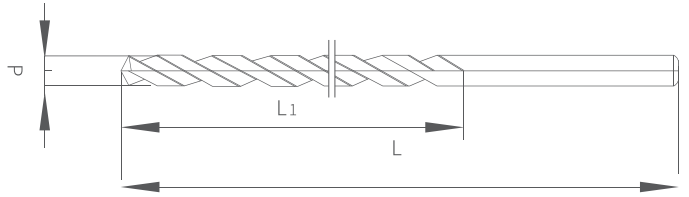

How to Order: PELSD + Size

Unit: mm

Size:d (h8)	L	L1
1.2-2.3	100	50
	150	75
	160	100
	200	100
2.4-4	150	75
	160	100
	200	150
	250	125
	250	200
	300	150
4.1-5	160	100
	200	150
	250	200
	300	240
	350	285
	400	300
5.1-6	160	100
	200	150
	250	200
	300	240
	350	285
	400	300
6.1-7	160	100
	200	150
	250	200
	300	240
	350	285
	400	300
7.1-8	160	100
	200	150

Size:d (h8)	L	L1
7.1-8	250	200
	300	240
	350	285
	400	300
	450	350
8.1-9	160	100
	200	150
	250	200
	300	240
	350	285
	400	300
9.1-10	200	150
	250	200
	300	240
	350	285
	400	300
	450	350
10.1-11	200	150
	250	200
	300	240
	350	285
	400	300
	450	350
11.1-12	250	200
	300	240
	350	285
	400	300
	450	350
12.1-13	250	200
	300	240
	350	285
	450	350

COSD

Straight Shank Twist Drill for Stainless Steel DIN338

HSS
CO5

Material

h8

Tolerance

135°

Point Angle

28°
~36°

Helix Angle

0.5-13

Diameter Range

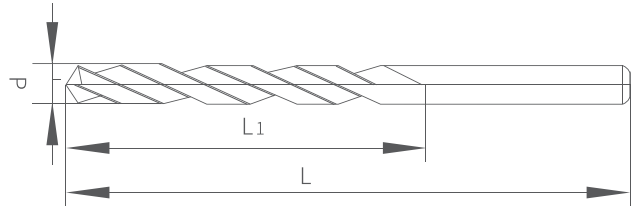

Unit: mm

How to Order: COSD + Size

Size:d (h8)	L	L1
0.50	22	6
0.82	30	10
0.85		
0.88		
0.90	32	11
0.92		
0.95		
0.98		
1.00	34	12
1.05		
1.10	36	14
1.15		
1.20		
1.25	38	16
1.30		
1.35		
1.40	40	18
1.45		
1.50		
1.55		
1.60	43	20
1.65		
1.70		
1.75		
1.80	46	22
1.85		
1.90		
1.95		
2.00	49	24
2.05		
2.10		
2.15	53	27
2.20		

Size:d (h8)	L	L1
2.25		
2.30	53	27
2.35		
2.40		
2.45		
2.50	57	30
2.55		
2.60		
2.65		
2.70		
2.75		
2.80		
2.85	61	33
2.90		
2.95		
3.0		
3.1	65	36
3.2		
3.3		
3.4		
3.5	70	39
3.6		
3.7		
3.8		
3.9		
4.0	75	43
4.1		
4.2		
4.3		
4.4		
4.5	80	47
4.6		
4.7		

Size:d (h8)	L	L1
4.8	86	52
4.9		
5.0		
5.1		
5.2		
5.3	93	57
5.4		
5.5		
5.6		
5.7		
5.8	101	63
5.9		
6.0		
6.1		
6.2		
6.3	109	69
6.4		
6.5		
6.6		
6.7		
6.8	117	75
6.9		
7.0		
7.1		
7.2		
7.3	125	81
7.4		
7.5		
7.6		
7.7		
7.8		
7.9		
8.0		
8.1		
8.2		
8.3		
8.4		
8.5		
8.6		
8.7		
8.8		
8.9		
9.0		

Size:d (h8)	L	L1
9.1	125	81
9.2		
9.3		
9.4		
9.5		
9.6	133	87
9.7		
9.8		
9.9		
10.0		
10.1	142	94
10.2		
10.3		
10.4		
10.5		
10.6	151	101
10.7		
10.8		
10.9		
11.0		
11.1	-	-
11.2		
11.3		
11.4		
11.5		
11.6		
11.7		
11.8		
11.9		
12.0		
12.1		
12.2		
12.3		
12.4		
12.5		
12.6		
12.7		
12.8		
12.9		
13.0		
-	-	-

COLSD

Straight Shank Long Twisit Drill for Stainless Steel DIN340



Material



Tolerance



Point Angle



Helix Angle

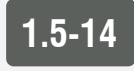

Diameter Range

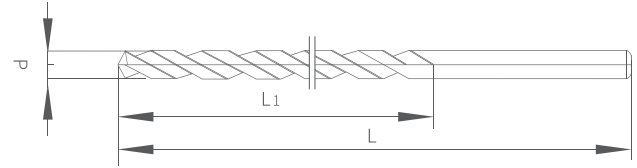

How to Order: COLSD + Size

Unit: mm

Size:d (h8)	L	L1
1.5	70	45
1.6	76	50
1.7		53
1.8	80	56
1.9		59
2.0	85	62
2.1		66
2.2	90	69
2.3		73
2.4	95	78
2.5		82
2.6	100	87
2.7		91
2.8	106	97
2.9		102
3.0	112	109
3.1		112
3.2	119	120
3.3		126
3.4	126	132
3.5		139
3.6	132	148
3.7		156
3.8	139	165
3.9		180
4.0	148	192
4.1		216
4.2	156	228
4.3		252
4.4	165	270
4.5		306
4.6	180	324
4.7		360

Size:d (h8)	L	L1
4.8	132	87
4.9		
5.0	139	91
5.1		
5.2	148	97
5.3		
5.4	156	102
5.5		
5.6	165	109
5.7		
5.8	180	120
5.9		
6.0	180	120
6.1		
6.2	192	132
6.3		
6.4	216	150
6.5		
6.6	216	150
6.7		
6.8	228	162
6.9		
7.0	252	180
7.1		
7.2	252	180
7.3		
7.4	270	192
7.5		
7.6	306	225
7.7		
7.8	306	225
7.9		
8.0	360	270

Size:d (h8)	L	L1
8.1	165	109
8.2		
8.3		
8.4		
8.5		
8.6	175	115
8.7		
8.8		
8.9		
9.0		
9.1		
9.2		
9.3		
9.4		
9.5		
9.6	184	121
9.7		
9.8		
9.9		
10.0		
10.1		
10.2		
10.3		
10.4		
10.5		
10.6	195	128
10.7		
10.8		
10.9		
11.0		
11.1		
11.2		

Size:d (h8)	L	L1
11.3	195	128
11.4		
11.5		
11.6		
11.7		
11.8	205	134
11.9		
12.0		
12.1		
12.2		
12.3		
12.4		
12.5		
12.6		
12.7		
12.8	214	140
12.9		
13.0		
13.1		
13.2		
13.3		
13.4		
13.5		
13.6		
13.7		
13.8	-	-
13.9		
14.0		
-	-	-

JSD

Jobber length Straights shank twist drills ANSI B94.11M

HSS/
HSSE

Material

h8

Tolerance

118°/135°

Point Angle

22°
~31°

Helix Angle

3/64-11/16

Diameter Range

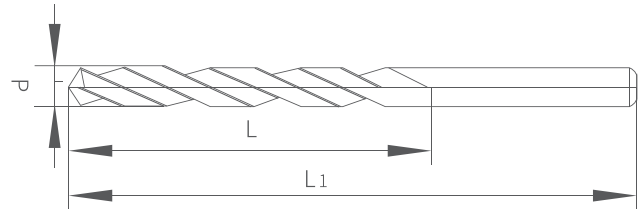

How to Order: JSD+ Size / JSD+ TiN+ Size

Unit: mm

Size:d (h8)	L	L1
3/64	3/4	1 3/4
1/16	7/8	1 7/8
5/64	1	2
3/32	1 1/4	2 1/4
7/64	1 1/2	2 5/8
1/8	1 5/8	2 3/4
9/64	1 3/4	2 7/8
5/32	2	3 1/8
11/64	2 1/8	3 1/4
3/16	2 5/16	3 1/2
13/64	2 7/17	3 5/8
7/32	2 1/2	3 3/4
15/64	2 5/8	3 7/8
1/4	2 3/4	2 1/4
17/64	2 7/8	4 1/8
9/32	2 15/16	4 1/4
19/64	3 1/16	4 3/8
5/16	3 3/16	4 1/2
21/64	3 5/16	4 5/8
11/32	3 7/16	4 3/4
23/64	3 1/2	4 7/8

Size:d (h8)	L	L1
3/8	3 5/8	5
25/64	3 3/4	5 1/8
13/32	3 7/8	5 1/4
27/64	3 15/16	5 3/8
7/16	4 1/16	5 1/2
29/64	4 3/16	5 5/8
15/32	4 5/16	5 3/4
31/64	4 3/8	5 7/8
1/2	4 1/2	6
33/64	4 13/16	6 5/8
17/32	4 13/16	6 5/8
35/64	4 13/16	6 5/8
9/16	4 13/16	6 5/8
37/64	4 13/16	6 5/8
19/32	5 3/16	7 1/8
39/64	5 3/16	7 1/8
5/8	5 3/16	7 1/8
41/64	5 3/16	7 1/8
21/32	5 3/16	7 1/8
43/64	5 5/8	7 5/8
11/16	5 5/8	7 5/8

TSD

Taper length Straights shank twist drills ANSI B94.11M

HSS/
HSSE

Material

h8

Tolerance

118°/135°

Point Angle

22°
~31°

Helix Angle

3/64-1/2

Diameter Range

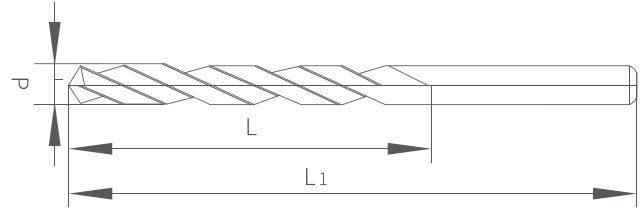

How to Order: TSD+ Size / TSD+ TiN+ Size

Unit: mm

Size:d (h8)	L	L1
3/64	1 1/8	2 1/4
1/16	1 3/4	3
5/64	2	3 3/4
3/32	2 1/4	4 1/4
7/64	2 1/2	4 5/8
1/8	3	5 3/8
9/64	3	5 3/8
5/32	3	5 3/8
11/64	3 3/8	5 3/4
3/16	3 3/8	5 3/4
13/64	3 5/8	6
7/32	3 5/8	6
15/64	3 3/4	6 1/8
1/4	3 3/4	6 1/8
17/64	3 7/8	6 1/4

Size:d (h8)	L	L1
9/32	3 7/8	6 1/4
19/64	4	6 3/8
5/16	4	6 3/8
21/64	4 1/8	6 1/2
11/32	4 1/8	6 1/2
23/64	4 1/4	6 3/4
3/8	4 1/4	6 3/4
25/64	4 3/8	7
13/32	4 3/8	7
27/64	4 5/8	7 1/4
7/16	4 5/8	7 1/4
29/64	4 3/4	7 1/2
15/32	4 3/4	7 1/2
31/64	4 3/4	7 3/4
1/2	4 3/4	7 3/4

SSD

Screw length Straights shank twist drills ANSI B94.11M



Material



Tolerance



Point Angle



Helix Angle



Diameter Range

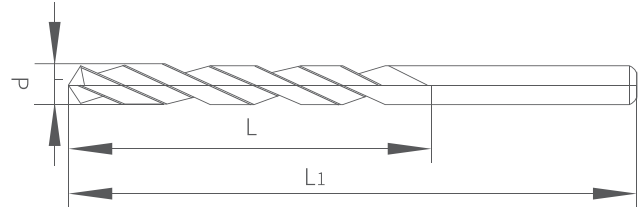

How to Order: SSD+ Size / SSD+ TiN+ Size

Unit: mm

Size:d (h8)	L	L1
3/64	1/2	1 3/8
1/16	5/8	1 5/8
5/64	11/16	1 11/16
3/32	3/4	1 3/4
7/64	13/16	1 13/16
1/8	7/8	1 7/8
9/64	15/16	1 15/16
5/32	1	2 1/16
11/64	1 1/16	2 1/8
3/16	1 1/8	2 3/16
13/64	1 3/16	2 1/4
7/32	1 1/4	2 3/8
15/64	1 5/16	2 7/16
1/4	1 3/8	2 1/2
17/64	1 7/16	2 5/8
9/32	1 1/2	2 11/16
19/64	1 9/16	2 3/4
5/16	1 5/8	2 13/16
21/64	1 11/16	2 15/16
11/32	1 11/16	3
23/64	1 3/4	3 1/16
3/8	1 13/16	3 1/8

Size:d (h8)	L	L1
25/64	1 7/8	3 1/4
13/32	1 15/16	3 5/16
27/64	2	3 3/8
7/16	2 1/16	3 7/16
29/64	2 1/8	3 9/16
15/32	2 1/8	3 5/8
31/64	2 3/16	3 11/16
1/2	2 1/4	3 3/4
33/64	2 3/8	3 7/8
17/32	2 3/8	3 7/8
35/64	2 1/2	4
9/16	2 1/2	4
37/64	2 5/8	4 1/8
19/32	2 5/8	4 1/8
39/64	2 3/4	4 1/4
5/8	2 3/4	4 1/4
41/64	2 7/8	4 1/2
21/32	2 7/8	4 1/2
43/64	2 7/8	4 1/2
11/16	2 7/8	4 1/2
45/64	3	4 3/4
23/32	3 1/8	5

TD

Taper Shank Twist Drill



Material



Tolerance



Point Angle



Helix Angle



Diameter Range

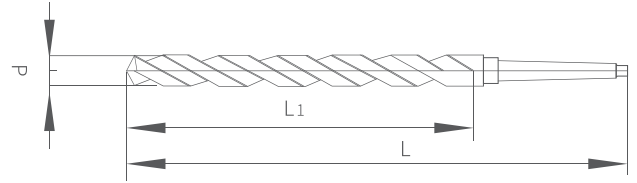

How to Order: TD + Size/ TD + TIN + Size

Unit: mm

Size:d (h8)	L	L1	Morse Taper
5.00	141	52	1
5.30			
5.40			
5.80	148	57	
6.00			
6.10			
6.70	156	63	
6.80			
7.00			
7.50	164	69	
7.80			
8.30			
8.40	172	75	
8.50			
8.60			
9.00	167	75	
9.50			
9.60			
9.70	175	81	
9.80			
10.00			
10.20	180	87	
10.70			
10.80			
11.00	180	94	
11.20			
11.50			
11.80	182	101	
11.90			
12.00			
12.20	182	101	
12.50			
12.80			
12.90			
13.00			
13.20			

Size:d (h8)	L	L1	Morse Taper
13.50	189	108	1
13.80			
13.90			
14.00	212	114	2
14.50			
14.75			
14.90			
15.00	218	120	
15.25			
15.50			
15.60	223	125	
15.75			
16.00			
16.10	228	130	
16.25			
16.50			
16.75	233	135	
16.90			
17.00			
17.25	238	140	
17.50			
17.75			
17.90	243	145	
18.00			
18.25			
18.50			
18.75			
18.90			
19.00			
19.25			
19.50			
19.75			
19.90			
20.00			
20.25			

Size:d (h8)	L	L1	Morse Taper
20.50	243	145	2
20.75			
20.90			
21.00			
21.25			
21.50	248	150	
21.75			
21.90			
22.00			
22.25			
22.50	253	155	
22.75			
22.90			
23.00			
23.10			276
23.50			
23.75			
24.00			
24.25			
24.50	281	165	
24.75			
24.90			
25.00			
25.25			286
25.50			
25.75			
25.90			
26.00	291	175	
26.25			
26.50			
26.75			
26.90			296
27.00			
27.25			
27.50			
27.75			
27.90			
28.00			
28.25			
28.50			
28.90			

Size:d (h8)	L	L1	Morse Taper
29.00	296	175	3
29.25			
29.50			
29.75			
29.90			
30.00	301	180	
30.25			
30.50			
30.75			
30.90			
31.00	306	173	
31.25			
31.50			
31.60			
32.00			334
32.00			
32.10			
32.50			
32.60			
33.00	339	180	
33.10			
33.50			
34.00			
34.10			344
34.50			
34.90			
35.00			
35.10			
35.50	349	185	
35.60			
36.00			
36.10			
36.50			
36.60			
36.90			
37.00			
37.50			
38.00			
38.50			
38.90			
39.00			

Size:d (h8)	L	L1	Morse Taper
39.50	349	185	4
40.00			
40.50	354	188	
41.00			
41.50			
41.90			
42.00			
42.50			
43.00	359	194	
43.50			
43.60			
44.00			
44.50			
44.90			
45.00	364	194	
45.50			
46.00			
46.50			
46.60			
47.00			
47.50	369	200	
48.00			
48.50			
49.00			
49.50			
49.60			
50.00	374	225	
50.20			
50.30			
50.50	412	230	
51.00			
52.00			
53.00	417	235	
53.10			
55.00			
55.10	422	235	
57.00			
57.10			
59.00			
60.00			

Size:d (h8)	L	L1	Morse Taper
60.10	427	240	5
62.00			
63.00			
63.10	432	245	
65.00			
65.10			
67.00			
67.10	437	250	
69.00			
70.00			
71.00			
71.10	442	255	
73.00			
74.00			
75.00			
75.1-76	447	260	
77.00			
78.00			
79.00			
80.00	514	265	
81.00			
82.00			
83.00			
83.00	519	270	
84.00			
85.00			
86.00			
87.00	524	275	
88.00			
89.00			
90.00			
91.00	529	280	
92.00			
93.00			
94.00			
95.00	534	280	
96.00			
97.00			
98.00			
98.00	534	280	
99.00			
100.00			

LTD

Taper Shank Long Twist Drill



Material



Tolerance



Point Angle



Helix Angle

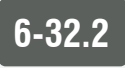

Diameter Range

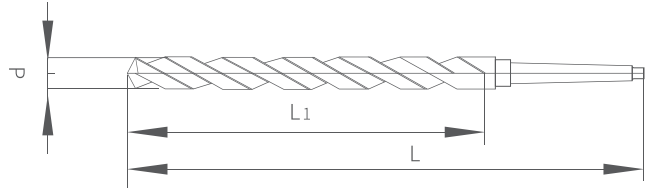

Unit: mm

How to Order: LTD + Size/ LTD + TIN + Size

Size:d (h8)	L	L1	Morse Taper
6.00	230	150	1
6.20			
6.50			
6.80			
7.00	235	150	
7.20			
7.50			
7.80			
8.00	240	150	
8.10			
8.50			
8.80			
9.00	245	150	
9.10			
9.50			
9.80			
10.00	250	170	
10.20			
10.50			
10.60			
11.00	255	175	
11.20			
11.50			
11.60			
11.90	260	180	
12.00			
12.20			
12.50			
12.60	265	185	
12.90			
13.00			
13.20			
13.50	265	185	
13.80			
13.90			
14.00			

Size:d (h8)	L	L1	Morse Taper
14.00	290	190	2
14.50			
14.75			
15.00			
15.25	295	195	
15.50			
15.60			
15.75			
16.00	300	200	
16.10			
16.25			
16.50			
16.75	305	205	
16.90			
17.00			
17.25			
17.50	310	210	
17.75			
17.90			
18.00			
18.25	320	220	
18.50			
18.75			
18.90			
19.00	330	230	
19.25			
19.50			
19.75			
19.90	335	235	
20.00			
20.25			
20.50			
20.75	335	235	
20.90			
21.00			
21.25			

Size:d (h8)	L	L1	Morse Taper	
21.50	335	235	2	
21.75				
21.90				
22.00				
22.25				
22.50	340	240	2	
22.75				
23.00				
23.10	360	240	3	
23.25				
23.50				
23.60	365	245		3
23.75				
24.00				
24.25				
24.50				
24.75				
24.90	375	255		
25.00				
25.25				
25.50				
25.75				
25.90				
26.00				
26.25				

Size:d (h8)	L	L1	Morse Taper		
26.50	375	255	3		
26.75	385	265		3	
26.90					
27.00					
27.25					
27.50					
27.75					
27.90	395	275			3
28.00					
28.25					
28.50					
28.75					
28.90					
29.00	405	285	3		
29.25					
29.50					
29.75					
29.90					
30.00					
30.10	405	285		3	
30.90					
31.00					
31.90					
32.00					
32.20					

ELTD

Taper Shank Extra-Long Twist Drill



Material



Tolerance



Point Angle



Helix Angle



Diameter Range

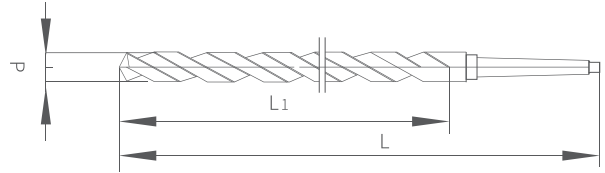

How to Order: ELTD + Size

Unit: mm

Size:d (h8)	L	L1	Morse Taper
6.0-8.0	300	210	1
	350	260	
	400	310	
	450	360	
	500	410	
	550	460	
	600	510	
8.1-8.5	300	210	
	350	260	
	400	310	
	450	360	
	500	410	
	550	460	
	600	510	
8.6-9	300	210	
	350	260	
	400	310	
	450	360	
	500	410	
	550	460	
	600	510	
9.1-9.5	300	210	
	350	260	
	400	310	
	450	360	
	500	410	
	550	460	
	600	510	
9.6-10	300	210	
	350	260	
	400	310	
	450	360	
	500	410	
	550	460	
	600	510	

Size:d (h8)	L	L1	Morse Taper
10.1-10.5	300	210	1
	350	260	
	400	310	
	450	360	
	500	410	
	550	460	
	600	510	
10.6-11	300	210	
	350	260	
	400	310	
	450	360	
	500	410	
	550	460	
	600	510	
11.1-11.5	300	210	
	350	260	
	400	310	
	450	360	
	500	410	
	550	460	
	600	510	
11.6-12	300	210	
	350	260	
	400	310	
	450	360	
	500	410	
	550	460	
	600	510	
12.1-12.5	300	210	
	350	260	
	400	310	
	450	360	
	500	410	
	550	460	
	600	510	

Size:d (h8)	L	L1	Morse Taper
12.6-13	300	210	1
	350	260	
	400	310	
	450	360	
	500	410	
	550	460	
13.1-13.5	600	510	
	300	210	
	350	260	
	400	310	
	450	360	
	500	410	
13.6-14	550	460	
	600	510	
	300	210	
	350	260	
	400	310	
	450	360	
14.1-15	500	410	
	550	460	
	600	510	
	350	250	
	400	300	
	450	350	
15.1-16	500	400	2
	550	450	
	600	500	
	350	245	
	400	295	
	450	345	
16.1-16.5	500	395	
	550	445	
	600	495	
	350	245	
	400	295	
	450	345	
16.6-17	500	395	
	550	445	
	600	495	
	350	245	
	400	295	
	450	345	

Size:d (h8)	L	L1	Morse Taper
16.6-17	450	345	2
	500	395	
	550	445	
	600	495	
	350	245	
17.1-18	400	295	
	450	345	
	500	395	
	550	445	
	600	495	
18.1-19	350	245	
	400	295	
	450	345	
	500	395	
	550	445	
19.1-20	600	495	
	350	245	
	400	295	
	450	345	
	500	395	
20.1-21	550	445	
	600	495	
	400	295	
	450	345	
	500	395	
21.1-22	550	445	
	600	495	
	400	295	
	450	345	
	500	395	
22.1-23	550	445	
	600	495	
	400	295	
	450	345	
	500	395	
23.1-24	600	495	3
	400	270	
	450	320	
	500	370	
	550	420	

Size:d (h8)	L	L1	Morse Taper
23.1-24	600	470	3
24.1-25	400	270	
	450	320	
	500	370	
	550	420	
	600	470	
25.1-26	450	320	
	500	370	
	550	420	
	600	470	
26.1-27	450	320	
	500	370	
	550	420	
	600	470	
27.1-28	450	320	
	500	370	
	550	420	
	600	470	
28.1-29	450	320	
	500	370	
	550	420	
	600	470	
29.1-30	450	320	
	500	370	
	550	420	
	600	470	
30.1-31	450	320	
	500	370	
	550	420	
	600	470	
31.1-32	450	320	
	500	370	
	550	420	
	600	470	
32.1-33	450	300	4
	500	350	
	550	400	
	600	450	
33.1-34	450	300	
	500	350	
	550	400	

Size:d (h8)	L	L1	Morse Taper
33.1-34	600	450	4
34.1-35	450	300	
	500	350	
	550	400	
	600	450	
	35.1-36	450	
500		350	
550		400	
600		450	
36.1-37	450	300	
	500	350	
	550	400	
	600	450	
37.1-38	450	300	
	500	350	
	550	400	
	600	450	
38.1-39	450	300	
	500	350	
	550	400	
	600	450	
39.1-40	450	300	
	500	350	
	550	400	
	600	450	
40.1-41	450	300	
	500	350	
	550	400	
	600	450	
41.1-42	450	300	
	500	350	
	550	400	
	600	450	
42.1-43	450	300	
	500	350	
	550	400	
	600	450	
43.1-44	450	300	
	500	350	
	550	400	
	600	450	

Size:d (h8)	L	L1	Morse Taper
44.1-45	450	300	4
	500	350	
	550	400	
	600	450	
45.1-46	450	300	
	500	350	
	550	400	
	600	450	
46.1-47	450	300	
	500	350	
	550	400	
	600	450	

Size:d (h8)	L	L1	Morse Taper
47.1-48	450	300	4
	500	350	
	550	400	
	600	450	
48.1-49	450	300	
	500	350	
	550	400	
	600	450	
49.1-50	450	300	
	500	350	
	550	400	
	600	450	

PELTD

Parabolic Flute Taper Shank Twist Drill for Deep Hole



Material



Tolerance



Point Angle



Helix Angle

6-50

Diameter Range

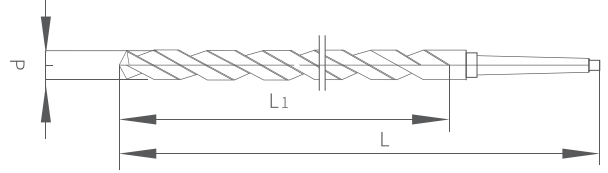

How to Order: PELTD + Size

Unit: mm

Size:d (h8)	L	L1	Morse Taper
6.0-8.0	300	210	1
	350	260	
	400	310	
	450	360	
	500	410	
	550	460	
	600	510	
8.1-8.5	300	210	
	350	260	
	400	310	
	450	360	
	500	410	
	550	460	
	600	510	
8.6-9	300	210	
	350	260	
	400	310	
	450	360	
	500	410	
	550	460	
	600	510	
9.1-9.5	300	210	
	350	260	
	400	310	
	450	360	
	500	410	
	550	460	
	600	510	
9.6-10	300	210	
	350	260	
	400	310	
	450	360	
	500	410	
	550	460	
	600	510	

Size:d (h8)	L	L1	Morse Taper
10.1-10.5	300	210	1
	350	260	
	400	310	
	450	360	
	500	410	
	550	460	
	600	510	
10.6-11	300	210	
	350	260	
	400	310	
	450	360	
	500	410	
	550	460	
	600	510	
11.1-11.5	300	210	
	350	260	
	400	310	
	450	360	
	500	410	
	550	460	
	600	510	
11.6-12	300	210	
	350	260	
	400	310	
	450	360	
	500	410	
	550	460	
	600	510	
12.1-12.5	300	210	
	350	260	
	400	310	
	450	360	
	500	410	
	550	460	
	600	510	

Size:d (h8)	L	L1	Morse Taper
12.6-13	300	210	1
	350	260	
	400	310	
	450	360	
	500	410	
	550	460	
13.1-13.5	600	510	
	300	210	
	350	260	
	400	310	
	450	360	
	500	410	
13.6-14	550	460	
	600	510	
	300	210	
	350	260	
	400	310	
	450	360	
14.1-15	500	410	
	550	460	
	600	510	
	350	250	
	400	300	
	450	350	
15.1-16	500	400	2
	550	450	
	600	500	
	350	245	
	400	295	
	450	345	
16.1-16.5	500	395	
	550	445	
	600	495	
	350	245	
	400	295	
	450	345	
16.6-17	500	395	
	550	445	
	600	495	
	350	245	
	400	295	
	450	345	

Size:d (h8)	L	L1	Morse Taper
16.6-17	450	345	2
	500	395	
	550	445	
	600	495	
17.1-18	350	245	
	400	295	
	450	345	
	500	395	
18.1-19	550	445	
	600	495	
	350	245	
	400	295	
19.1-20	450	345	
	500	395	
	550	445	
	600	495	
20.1-21	400	295	
	450	345	
	500	395	
	550	445	
21.1-22	600	495	
	400	295	
	450	345	
	500	395	
22.1-23	550	445	
	600	495	
	400	295	
	450	345	
23.1-24	500	370	3
	450	320	
	550	420	

Size:d (h8)	L	L1	Morse Taper
23.1-24	600	470	3
24.1-25	400	270	
	450	320	
	500	370	
	550	420	
	600	470	
25.1-26	450	320	
	500	370	
	550	420	
	600	470	
26.1-27	450	320	
	500	370	
	550	420	
	600	470	
27.1-28	450	320	
	500	370	
	550	420	
	600	470	
28.1-29	450	320	
	500	370	
	550	420	
	600	470	
29.1-30	450	320	
	500	370	
	550	420	
	600	470	
30.1-31	450	320	
	500	370	
	550	420	
	600	470	
31.1-32	450	320	
	500	370	
	550	420	
	600	470	
32.1-33	450	300	4
	500	350	
	550	400	
	600	450	
33.1-34	450	300	
	500	350	
	550	400	

Size:d (h8)	L	L1	Morse Taper
33.1-34	600	450	4
34.1-35	450	300	
	500	350	
	550	400	
	600	450	
	650	500	
35.1-36	450	300	
	500	350	
	550	400	
	600	450	
36.1-37	450	300	
	500	350	
	550	400	
	600	450	
37.1-38	450	300	
	500	350	
	550	400	
	600	450	
38.1-39	450	300	
	500	350	
	550	400	
	600	450	
39.1-40	450	300	
	500	350	
	550	400	
	600	450	
40.1-41	450	300	
	500	350	
	550	400	
	600	450	
41.1-42	450	300	
	500	350	
	550	400	
	600	450	
42.1-43	450	300	
	500	350	
	550	400	
	600	450	
43.1-44	450	300	
	500	350	
	550	400	
	600	450	

Size:d (h8)	L	L1	Morse Taper
44.1-45	450	300	4
	500	350	
	550	400	
	600	450	
45.1-46	450	300	
	500	350	
	550	400	
	600	450	
46.1-47	450	300	
	500	350	
	550	400	
	600	450	

Size:d (h8)	L	L1	Morse Taper
47.1-48	450	300	4
	500	350	
	550	400	
	600	450	
48.1-49	450	300	
	500	350	
	550	400	
	600	450	
49.1-50	450	300	
	500	350	
	550	400	
	600	450	

COTD

Taper Shank Twist Drill for Stainless Steel



Material



Tolerance



Point Angle



Helix Angle

5-32

Diameter Range

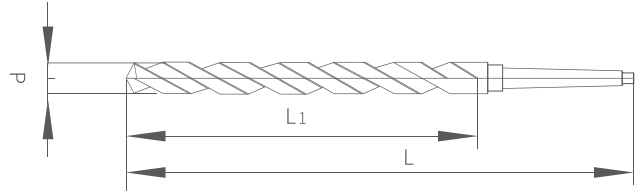

Unit: mm

How to Order: COTD + Size

Size:d (h8)	L	L1	Morse Taper
5.00	141	52	1
5.30			
5.40			
5.80	148	57	
6.00			
6.10			
6.70	156	63	
6.80			
7.00			
7.50	164	69	
7.80			
8.30			
8.40	172	75	
8.50			
8.60			
9.00	167	75	
9.50			
9.60			
9.70	175	81	
9.80			
10.00			
10.20	183	87	
10.70			
10.80			
11.00	175	94	
11.20			
11.50			
11.80	182	101	
11.90			
12.00			
12.20			
12.50			
12.80			
12.90			
13.00			
13.20			

Size:d (h8)	L	L1	Morse Taper
13.50	189	108	2
13.80			
13.90			
14.00	212	114	
14.50			
14.75			
14.90	218	120	
15.00			
15.25			
15.50	223	125	
15.60			
15.75			
16.00	228	130	
16.10			
16.25			
16.50	233	135	
16.75			
16.90			
17.00	238	140	
17.25			
17.50			
17.75	243	145	
17.90			
18.00			
18.25			
18.50			
18.75			
18.90			
19.00			
19.25			
19.50			
19.75			
19.90			
20.00			
20.25			

Size:d (h8)	L	L1	Morse Taper
20.50	243	145	2
20.75			
20.90			
21.00			
21.25	248	150	
21.50			
21.75			
21.90			
22.00			
22.25			
22.50	253	155	
22.75			
22.90			
23.00			
23.10	276		
23.25			
23.50			
23.75			
24.00	281	160	3
24.25			
24.50			
24.75			
24.90			
25.00			
25.25	286	165	
25.50			
25.75			
25.90			
26.00			
26.25			

Size:d (h8)	L	L1	Morse Taper
26.50	286	165	3
26.75	291	170	
26.90			
27.00			
27.25			
27.50			
27.75			
27.90	296	175	
28.00			
28.25			
28.50			
28.75			
28.90			
29.00	301	180	
29.25			
29.50			
29.75			
29.90			
30.00			
30.25	306	185	
30.50			
30.75			
30.90			
31.00			
31.25			
31.50	334		4
31.60			
31.75	-	-	-
32.00	-	-	-
-	-	-	-

COLTD

Taper Shank Long Twist Drill for Stainless Steel



Material



Tolerance



Point Angle



Helix Angle



Diameter Range

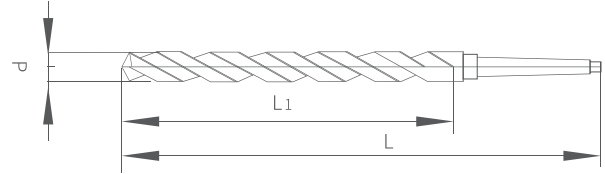

How to Order: COLTD + Size

Unit: mm

Size:d (h8)	L	L1	Morse Taper
6.00	230	150	1
6.20			
6.50			
6.80			
7.00	235	150	
7.20			
7.50			
7.80			
8.00	240	150	
8.10			
8.50			
8.80			
9.00	245	150	
9.10			
9.50			
9.80			
10.00	250	170	
10.20			
10.50			
10.60			
11.00	255	175	
11.20			
11.50			
11.60			
11.90	260	180	
12.00			
12.20			
12.50			
12.60	265	185	
12.90			
13.00			
13.20			
13.50	265	185	
13.80			
13.90			
14.00			

Size:d (h8)	L	L1	Morse Taper
14.00	290	190	2
14.50			
14.75			
15.00			
15.25	295	195	
15.50			
15.60			
15.75			
16.00	300	200	
16.10			
16.25			
16.50			
16.75	305	205	
16.90			
17.00			
17.25			
17.50	310	210	
17.75			
17.90			
18.00			
18.25	320	220	
18.50			
18.75			
18.90			
19.00	330	230	
19.25			
19.50			
19.75			
19.90	335	235	
20.00			
20.25			
20.50			
20.75	335	235	
20.90			
21.00			
21.25			

Size:d (h8)	L	L1	Morse Taper
21.50	335	235	2
21.75			
21.90			
22.00			
22.25			
22.50	340	240	2
22.75			
23.00			
23.10	360	240	3
23.25			
23.50			
23.60	365	245	3
23.75			
24.00			
24.25			
24.50			
24.75			
24.90			
25.00	375	255	3
25.25			
25.50			
25.75			
25.90			
26.00			
26.25			

Size:d (h8)	L	L1	Morse Taper			
26.50	375	255	3			
26.75	385	265		3		
26.90						
27.00						
27.25						
27.50						
27.75	395	275			3	
27.90						
28.00						
28.25						
28.50						
28.75	405	285				3
28.90						
29.00						
29.25						
29.50						
29.75						
29.90						
30.00	405	285	3			
30.10						
30.90						
31.00						
31.90						
32.00						
32.20						

NOS

Noss Drill



Material



Tolerance



Point Angle



Helix Angle



Diameter Range

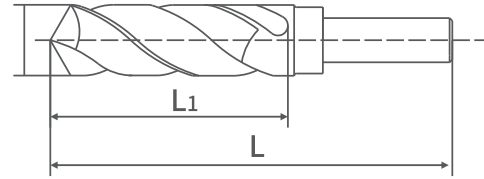

Unit: mm

How to Order: NOS + Size

Size:d (h8)	L	L1
12.5		
13.0		
13.5		
14.0		
14.5		
15.0		
15.5		
16.0		
16.5		
17.0		
17.5		
18.0		
18.5		
19.0		
19.5		
20.0	76.2	152.4
20.5		
21.0		
21.5		
22.0		
22.5		
23.0		
23.5		
24.0		
24.5		
25.0		
25.5		
26.0		
26.5		
27.0		
27.5		
28.0		

Size:d (h8)	L	L1
28.5		
29.0		
29.5		
30.0		
30.5		
31.0		
31.5		
32.0		
32.5		
33.0		
33.5		
34.0		
34.5		
35.0		
35.5		
36.0	76.2	152.4
36.5		
37.0		
37.5		
38.0		
38.5		
39.0		
39.5		
40.0		
40.5		
41.0		
41.5		
42-43.5		
44-44.5		
45-46.5		
47-49.5		
50.0		

ACDT

A Type Center Drill with TiN Coating



Material



Tolerance



Point Angle



Helix Angle



Diameter Range

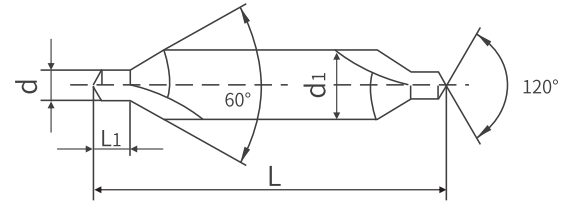

Unit: mm

How to Order: ACDT + Size

Size:d (h8)	L	L1	d1
A1	35	1.3	4
A1.5	35	2	4
A2	40	2.5	5
A2.5	45	3.1	6

Size:d (h8)	L	L1	d1
A3	50	3.9	8
A4	55	5.0	10
A5	63	6.3	12
A6	65	7.0	14

BCDT

B Type Center Drill with TiN Coating



Material



Tolerance



Point Angle



Helix Angle



Diameter Range

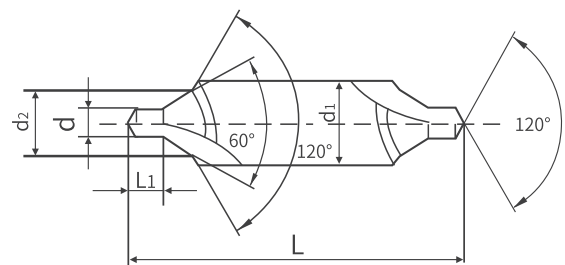

Unit: mm

How to Order: BCDT + Size

Size:d (h8)	L	L1	d1
B1	35.5	1.3	4
B1.5	45	2.0	6.3
B2	50	2.5	8
B2.5	56	3.9	10

Size:d (h8)	L	L1	d1
B3	56	3.9	11.2
B4	62	5	14
B5	70	6.3	18
B6	75	8	20

BSCDT

BS Type Center Drill with TiN Coating



Material



Tolerance



Point Angle



Helix Angle



Diameter Range

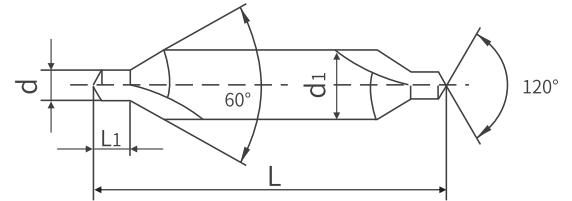

Unit: mm

How to Order: BSCDT + Size

Size:d (h8)	L	d	d1
BS-1	1-1/2"	3/64"	1/8"
BS-2	1-3/4"	1/16"	3/16"
BS-3	2"	3/32"	1/4"
BS-4	2-1/4"	1/8"	5/16"

Size:d (h8)	L	d	d1
BS-5	2-1/2"	3/16"	7/16"
BS-6	3"	1/4"	5/8"
BS-7	3-1/2"	5/16"	3/4"

COSPDT

HSS-E Spot Drill with TiN Coating



Material



Tolerance



Point Angle



Helix Angle

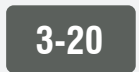

Diameter Range

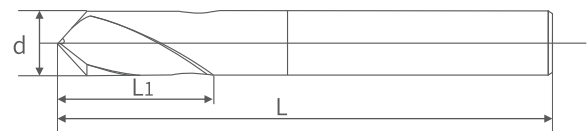

Unit: mm

How to Order: COSPDT + Size

Size:d (h8)	L	L1
3	50	10
4	52	12
5	60	15
6	66	20
8	79	25
10	89	25

Size:d (h8)	L	L1
12	102	30
14	115	35
16	115	35
18	130	40
20	131	40
-	-	-

TAPS

60 YEARS FOCUS INNOVATION



ISHTB

Straight Flute Tap ISO529 for Blind Hole

HSS-E HSS
 <M20 ≥M20

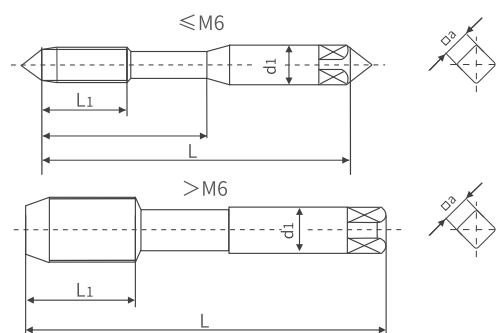

How to Order: ISHTB + Size/ ISHTB + TiN +Size

Unit: mm

Size	Thread Pitch(p)	L	L1	d1	a
M1	0.25	38.5	5.5	2.5	2
M1.2	0.25	38.5	5.5	2.5	2
M1.4	0.30	40	7	2.5	2
M1.6	0.35	41	8	2.5	2
M1.8	0.35	41	8	2.5	2
M2	0.40	41	8	2.5	2
M2.5	0.45	44.5	9.5	2.5	2.24
M3	0.50	48	11	3.15	2.5
M3.5	0.35	50	13	3.55	2.8
M4	0.70	53	13	4	3.15
M4.5	0.80	53	13	4.5	3.55
M5	0.80	58	16	5	4
M6	1.00	66	19	6.3	5
M8	1.25	72	22	6.3	5
M8×1	1.00	72	22.0	6.30	5.00
M10	1.50	80	24.0	8.00	6.30
M10×1.25	1.25	80	24.0	8.00	6.30
M10×1	1.00	80	24.0	8.00	6.30
M12	1.75	89	29.0	9.00	7.10
M12×1.5	1.50	89	29.0	9.00	7.10
M12×1.25	1.25	89	29.0	9.00	7.10
M12×1	1.00	80	22.0	9.00	7.10
M14	2.00	95	30.0	11.2	9.00
M14×1.5	1.50	95	30.0	11.2	9.00
M14×1.25	1.25	95	30.0	11.2	9.00
M14×1	1.00	87	22.0	11.2	9.00
M16	2.00	102	32.0	12.5	10.0
M16×1.5	1.50	102	32.0	12.5	10.0
M16×1	1.00	92	22.0	12.5	10.0
M18	2.50	112	37.0	14.0	11.2

Size	Thread Pitch(p)	L	L1	d1	a
M18×2	2.00	112	37.0	14.0	11.2
M18×1.5	1.50	112	37.0	14.0	11.2
M18×1	1.00	97	22.0	14.0	11.2
M20	2.50	112	37.0	14.0	11.2
M20×2	2.00	112	37.0	14.0	11.2
M20×1.5	1.50	112	37.0	14.0	11.2
M20×1	1.00	102	22.0	14.0	11.2
M22	2.50	118	38.0	16.0	12.5
M22×2	2.00	118	38.0	16.0	12.5
M22×1.5	1.50	118	38.0	16.0	12.5
M22×1	1.00	109	24.0	16.0	12.5
M24	3.00	130	45.0	18.0	14.0
M24×2	2.00	130	45.0	18.0	14.0
M24×1.5	1.50	130	45.0	18.0	14.0
M24×1	1.00	114	24.0	18.0	14.0
M27	3.00	135	45.0	20.0	16.0
M27×2	2.00	127	37.0	20.0	16.0
M27×1.5	1.50	127	37.0	20.0	16.0
M27×1	1.00	120	25.0	20.0	16.0
M30	3.50	138	48.0	20.0	16.0
M30×2	2.00	127	37.0	20.0	16.0
M30×1.5	1.50	127	37.0	20.0	16.0
M30×1	1.00	120	25.0	20.0	16.0
M33	3.50	151	51.0	22.4	18.0
M33×2	2.00	137	37.0	22.4	18.0
M33×1.5	1.50	137	37.0	22.4	18.0
M36	4.00	162	57.0	25.0	20.0
M36×3	3.00	162	57.0	25.0	20.0
M36×2	2.00	144	39.0	25.0	20.0
M36×1.5	1.50	144	39.0	25.0	20.0

Comparison table of tap precision tolerance

Tolerance Code of Tap	Tolerance Code of Internal Thread
H1	4H、5H
H2	5G、6H
H3	6G、7H、7G

Bottom hole dia=External dia-Thread Pitch

Sample: M10*1.5 tap

Bottom hole=10(External)-1.5(thread pitch)=8.5

ISHTT

Straight Flute Machine Tap ISO529 for Through Hole

HSS-E HSS
 <M20 ≥M20

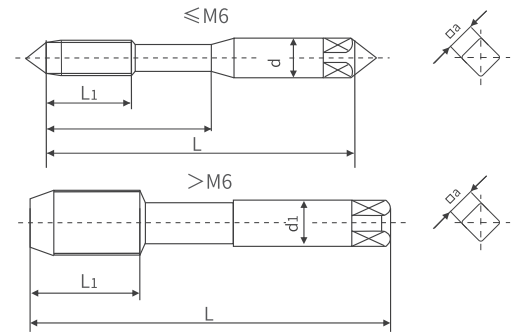

How to Order: ISHTT + Size/ ISHTT + TiN + Size

Unit: mm

Size	Thread Pitch(p)	L	L1	d1	a
M1	0.25	38.5	5.5	2.5	2
M1.2	0.25	38.5	5.5	2.5	2
M1.4	0.30	40	7	2.5	2
M1.6	0.35	41	8	2.5	2
M1.8	0.35	41	8	2.5	2
M2	0.40	41	8	2.5	2
M2.5	0.45	44.5	9.5	2.5	2.24
M3	0.50	48	11	3.15	2.5
M3.5	0.35	50	13	3.55	2.8
M4	0.70	53	13	4	3.15
M4.5	0.80	53	13	4.5	3.55
M5	0.80	58	16	5	4
M6	1.00	66	19	6.3	5
M8	1.25	72	22	6.3	5
M8×1	1.00	72	22.0	6.30	5.00
M10	1.50	80	24.0	8.00	6.30
M10×1.25	1.25	80	24.0	8.00	6.30
M10×1	1.00	80	24.0	8.00	6.30
M12	1.75	89	29.0	9.00	7.10
M12×1.5	1.50	89	29.0	9.00	7.10
M12×1.25	1.25	89	29.0	9.00	7.10
M12×1	1.00	80	22.0	9.00	7.10
M14	2.00	95	30.0	11.2	9.00
M14×1.5	1.50	95	30.0	11.2	9.00
M14×1.25	1.25	95	30.0	11.2	9.00
M14×1	1.00	87	22.0	11.2	9.00
M16	2.00	102	32.0	12.5	10.0
M16×1.5	1.50	102	32.0	12.5	10.0
M16×1	1.00	92	22.0	12.5	10.0
M18	2.50	112	37.0	14.0	11.2

Size	Thread Pitch(p)	L	L1	d1	a
M18×2	2.00	112	37.0	14.0	11.2
M18×1.5	1.50	112	37.0	14.0	11.2
M18×1	1.00	97	22.0	14.0	11.2
M20	2.50	112	37.0	14.0	11.2
M20×2	2.00	112	37.0	14.0	11.2
M20×1.5	1.50	112	37.0	14.0	11.2
M20×1	1.00	102	22.0	14.0	11.2
M22	2.50	118	38.0	16.0	12.5
M22×2	2.00	118	38.0	16.0	12.5
M22×1.5	1.50	118	38.0	16.0	12.5
M22×1	1.00	109	24.0	16.0	12.5
M24	3.00	130	45.0	18.0	14.0
M24×2	2.00	130	45.0	18.0	14.0
M24×1.5	1.50	130	45.0	18.0	14.0
M24×1	1.00	114	24.0	18.0	14.0
M27	3.00	135	45.0	20.0	16.0
M27×2	2.00	127	37.0	20.0	16.0
M27×1.5	1.50	127	37.0	20.0	16.0
M27×1	1.00	120	25.0	20.0	16.0
M30	3.50	138	48.0	20.0	16.0
M30×2	2.00	127	37.0	20.0	16.0
M30×1.5	1.50	127	37.0	20.0	16.0
M30×1	1.00	120	25.0	20.0	16.0
M33	3.50	151	51.0	22.4	18.0
M33×2	2.00	137	37.0	22.4	18.0
M33×1.5	1.50	137	37.0	22.4	18.0
M36	4.00	162	57.0	25.0	20.0
M36×3	3.00	162	57.0	25.0	20.0
M36×2	2.00	144	39.0	25.0	20.0
M36×1.5	1.50	144	39.0	25.0	20.0

Comparison table of tap precision tolerance

Tolerance Code of Tap	Tolerance Code of Internal Thread
H1	4H、5H
H2	5G、6H
H3	6G、7H、7G

Bottom hole dia=External dia-Thread Pitch

Sample: M10*1.5 tap

Bottom hole=10(External)-1.5(thread pitch)=8.5

DIN352HT

Hand Tap Set

HSS-E

HSS

<M20

≥M20

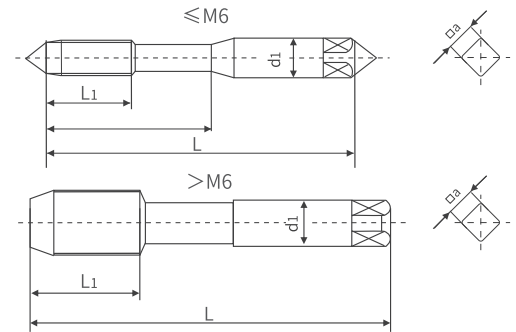
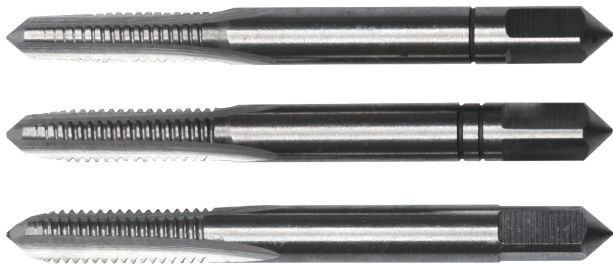

How to Order: DIN352HT + Size/ DIN352HT + TiN + Size

Unit: mm

Size	Thread Pitch(p)	L	L1	d1
M1	0.25	32	5.5	2.5
M1.1	0.25	32	5.5	2.5
M1.2	0.25	32	5.5	2.5
M1.4	0.3	32	7.0	2.5
M1.6	0.35	32	8.0	2.5
M1.7	0.35	32	8.0	2.5
M1.8	0.35	32	8.0	2.5
M2	0.4	36	8.0	2.8
M2.2	0.45	36	9.0	2.8
M2.3	0.4	36	9.0	2.8
M2.5	0.45	40	9.0	2.8
M2.6	0.45	40	9.0	2.8
M3	0.5	40	11.0	3.5
M3.5	0.6	45	13.0	4.0
M4	0.7	45	13.0	4.5
M4.5	0.75	50	16.0	6.0
M5	0.8	50	16.0	6.0
M6	1	50	19.0	6.0
M7	1	50	19.0	6.0
M8	1.25	56	22.0	6.0
M9	1.25	63	22.0	7.0
M10	1.5	70	24.0	7.0
M11	1.5	70	24.0	8.0
M12	1.75	75	29.0	9.0
M14	2	80	30.0	11.0
M16	2	80	32.0	12.0
M18	2.5	95	40.0	14.0
M20	2.5	95	40.0	16.0
M22	2.5	100	40.0	18.0
M24	3	110	50.0	18.0

Size	Thread Pitch(p)	L	L1	d1
M27	3	110	50.0	20.0
M30	3.5	125	56.0	22.0
M33	3.5	125	56.0	25.0
M36	4	150	63.0	28.0
M39	4	150	63.0	32.0
M42	4.5	150	63.0	32.0
M45	4.5	160	70.0	36.0
M48	5	180	75.0	36.0
M52	5	180	75.0	40.0
M56	5.5	200	85.0	45.0
M60	5.5	200	85.0	45.0
M64	6	220	90.0	50.0
M68	6	220	90.0	50.0

DIN2181HT

Hand Tap Set

HSS-E **HSS**
 <M20 ≥M20

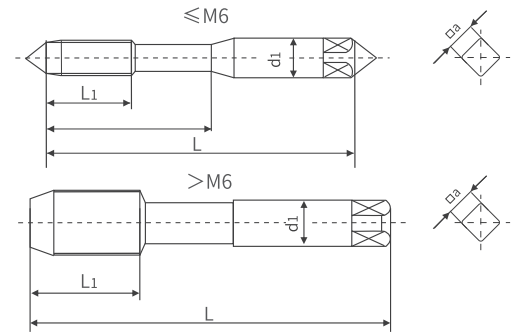

How to Order: DINDIN2181HT+Size/ DINDIN2181HT + TiN +Size

Unit: mm

Size	Thread Pitch(p)	L	L1	d1
M3	0.35	40	9	3.5
M4	0.5	45	10	4.5
M4	0.35	45	10	4.5
M5	0.5	50	12	6
M6	0.75	50	14	6
M6	0.5	50	14	6
M7	0.75	50	14	6
M8	1	56	22	6
M8	0.75	50	19	6
M8	0.5	50	19	6
M9	1	63	22	7
M10	1.25	70	24	7
M10	1	63	20	7
M10	0.75	63	20	7
M11	1	63	20	8
M12	1.5	70	22	9
M12	1.25	70	22	9
M12	1	70	22	9
M13	1.5	70	22	11
M13	1	70	22	11
M14	1.5	70	22	11
M14	1.25	70	22	11
M14	1	70	22	11
M15	1.5	70	22	12
M15	1	70	22	12
M16	1.5	70	22	12
M16	1.25	70	22	12
M16	1	70	22	12
M18	2	80	22	14
M18	1.25	80	22	14

Size	Thread Pitch(p)	L	L1	d1
M18	1	80	22	14
M20	2	80	22	16
M20	1.5	80	22	16
M20	1.25	80	22	16
M20	1	80	22	16
M22	2	80	22	18
M22	1.5	80	22	18
M22	1	80	22	18
M24	2	90	22	18
M24	1.5	90	22	18
M24	1	90	22	18
M25	1.5	90	22	18
M26	2	90	22	18
M26	1.5	90	22	18
M27	2	90	22	20
M27	1.5	90	22	20
M28	2	90	22	20
M28	1.5	90	22	20
M30	2	90	22	22
M30	1.5	90	22	22
M32	1.5	90	22	22
M33	2	100	25	25
M33	1.5	100	25	25
M34	1.5	100	25	28
M35	1.5	100	25	28
M36	3	125	40	28
M36	2	125	40	28
M36	1.5	100	25	28
M38	1.5	100	25	28
M39	3	125	40	32
M39	2	125	40	32
M40	2	125	40	32
M40	1.5	110	25	32
M42	3	125	40	32
M42	2	125	40	32
M42	1.5	110	25	32
M45	3	125	40	36
M45	2	125	40	36
M45	1.5	110	25	36
M48	3	140	40	36
M48	2	140	40	36
M48	1.5	140	40	36
M50	1.5	140	40	36
M52	3	140	40	40
M52	2	140	40	40
M52	1.5	140	40	40

ISSFT

Spiral Flute Machine Tap ISO 529

HSS-E

HSS

<M20

≥M20

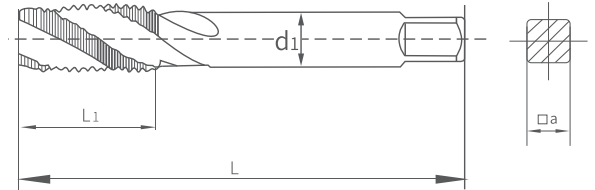

How to Order: ISSFT + Size/ ISSFT + TiN + Size

Unit: mm

Size	Thread Pitch	L	L ₁	d ₁	a
M2	0.40	41	8.0	2.5	2.0
M2.5	0.45	44.5	9.5	2.8	2.24
M3	0.50	48	13	3.15	2.5
M4	0.70	53	15	4.0	3.15
M5	0.80	58	18.5	5.0	4.0
M6	1.00	66	22.5	6.3	5.0
M8	1.25	72	22	6.3	5.0
M8X1	1.00	72	22	6.3	5.0
M10	1.50	80	24	8.0	6.3
M10X1.25	1.25	80	24	8.0	6.3
M10X1	1.00	80	24	8.0	6.3
M12	1.75	89	29	9.0	7.1
M12X1.5	1.50	89	29	9.0	7.1
M12X1.25	1.25	89	29	9.0	7.1
M12X1	1.00	80	22	9.0	7.1
M14	2.00	95	30	11.2	9.0
M14X1.5	1.50	95	30	11.2	9.0
M14X1.25	1.25	95	30	11.2	9.0
M14X1	1.00	87	22	11.2	9.0
M16	2.00	102	32	12.5	10
M16X1.5	1.50	102	32	12.5	10
M16X1	1.00	92	22	12.5	10
M18	2.50	112	37	14	11.2
M18X2	2.00	112	37	14	11.2
M18X1.5	1.50	112	37	14	11.2
M18X1	1.00	97	22	14	11.2
M20	2.50	112	37	14	11.2
M20X2	2.00	112	37	14	11.2

Size	Thread Pitch	L	L1	d1	a
M20X1.5	1.5	112	37	14	11.2
M20X1	1.0	102	22	14	11.2
M22	2.5	118	38	16	12.5
M22X2	2.0	118	38	16	12.5
M22X1.5	1.5	118	38	16	12.5
M22X1	1.0	109	24	16	12.5
M24	3.0	130	45	18	14
M24X2	2.0	130	45	18	14
M24X1.5	1.5	130	45	18	14
M24X1	1.0	114	24	18	14
M27	3.0	135	45	20	16
M27X2	2.0	127	37	20	16
M27X1.5	1.5	127	37	20	16
M27X1	1.0	120	25	20	16

ALSFT

Spiral Flute Machine Tap for Aluminum

HSS-E

HSS

<M20

≥M20

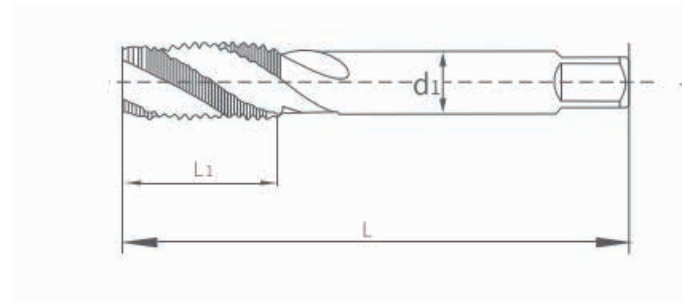

How to Order: ALSFT+Size/ ALSFT + TiN +Size

Unit: mm

Size	L	L1	D1
M2	43	11	
M2.5	47	13	
M3	49	5	
M3.5	52	6	
M4	56	7	
M5	63	8	
M6	68	10	
M8	70	13	
M10	75	15	
M12	82	18	

CDT

Combination Drill Tap

HSS-E

HSS

<M20

≥M20

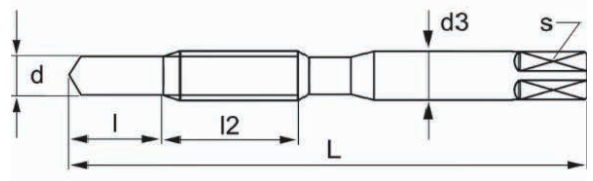

How to Order: CDT + Size/ CDT + TiN + Size

Unit: mm

Size	L	l2	l	d
M3*0.5	66	13	4	2.5
M4*0.7	67	14	5	3.3
M5*0.8	68	15	6	4.2
M6*1	69	16	7	5
M8*1.25	71	18	9	6.8
M10*1.5	73	20	11	8.5

CDTANSI

Combination Drill Tap ANSI

HSS-E HSS
 <M20 ≥M20

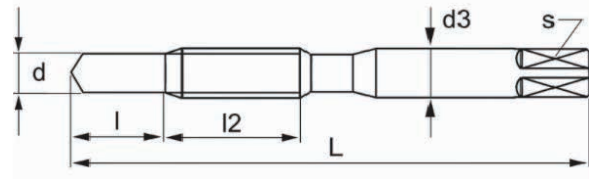

How to Order: CDTANSI+Size/ CDTANSI + TiN +Size

Unit: mm

Size	L	l2	l	d
M10*1.5	73	20	11	8.5
M3*0.5	1-15/16	13/32	9/32	0.1015
M3.5*0.6	2	7/16	5/16	0.118
M4*0.7	2-1/8	1/2	3/8	0.134
M4.5*0.75	2-3/8	5/8	13/32	0.152
M5*0.8	2-3/8	5/8	13/32	0.17
M6*1	2-1/2	25/32	17/32	0.203
M7*1	2-27/32	15/16	11/16	0.242
M8*1.25	2-27/32	15/16	11/16	0.2735
M10*1.5	3-3/8	1-1/16	13/16	0.344
M12*1.75	4-1/16	1-3/8	1-1/8	0.414
4-40NC	1-7/8	9/16	1/4	0.089
4-48NF	1-7/8	9/16	1/4	0.093
5-40NC	1-15/16	5/8	9/32	0.1015
5-44NF	1-15/16	5/8	9/32	0.104
6-32NC	2	11/16	5/16	0.1095
6-40NF	2	11/16	5/16	0.115
8-32NC	2-1/8	3/4	3/8	0.136
8-36NF	2-1/8	3/4	3/8	0.1385
10-24NC	2-3/8	7/8	13/32	0.152
10-32NF	2-3/8	7/8	13/32	0.161
12-24NC	2-3/8	7/8	15/32	0.177
12-28NF	2-3/8	7/8	15/32	0.1835
1/4-20NC	2-1/2	15/16	17/32	0.201
1/4-28NF	2-1/2	15/16	17/32	0.2175
5/16-18NC	3	1-1/8	11/16	0.257
5/16-24NF	3	1-1/8	11/16	0.272
3/8-16NC	3-1/2	1-1/4	13/16	0.3125
3/8-24NF	3-1/2	1-1/4	13/16	0.3345
7/16-14NC	3-7/8	1-7/16	1	0.368
7/16-20NF	3-7/8	1-7/16	1	0.389
1/2-13NC	4-1/4	1-21/34	1-1/8	0.425
1/2-20NF	4-1/4	1-21/34	1-1/8	0.451

ISSPPT

Spiral Point Tap ISO 529

HSS-E

HSS

<M20

≥M20

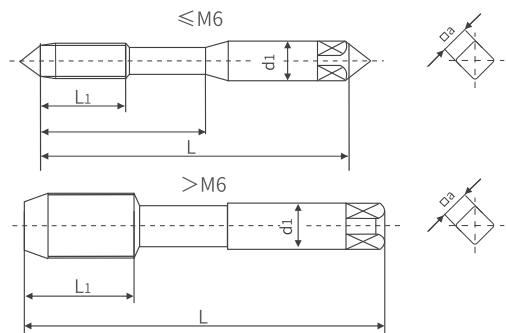

How to Order: ISSPPT + Size/ ISSPPT + TiN +Size

Unit: mm

Size	Thread Pitch	L	L1	d1	a
M3	0.50	48	11	3.15	2.5
M4	0.70	53	13	4.0	3.15
M5	0.80	58	16	5.0	4.0
M6	1.00	66	19	6.3	5.0
M8	1.25	72	22	6.3	5.0
M8X1	1.00	72	22	6.3	5.0
M10	1.50	80	24	8.0	6.3
M10X1.25	1.25	80	24	8.0	6.3
M10X1	1.00	80	24	8.0	6.3
M12	1.75	89	29	9.0	7.1
M12X1.5	1.50	89	29	9.0	7.1
M12X1.25	1.25	89	29	9.0	7.1
M12X1	1.00	80	22	9.0	7.1
M14	2.00	95	30	11.2	9.0
M14X1.5	1.50	95	30	11.2	9.0
M14X1.25	1.25	95	30	11.2	9.0
M14X1	1.00	87	22	11.2	9.0
M16	2.00	102	32	12.5	10
M16X1.5	1.50	102	32	12.5	10
M16X1	1.00	92	22	12.5	10
M18	2.50	112	37	14	11.2
M18X2	2.00	112	37	14	11.2
M18X1.5	1.50	112	37	14	11.2
M18X1	1.00	97	22	14	11.2
M20	2.50	112	37	14	11.2
M20X2	2.00	112	37	14	11.2
M20X1.5	1.5	112	37	14	11.2
M20X1	1.0	102	22	14	11.2

Size	Thread Pitch	L	L ₁	d ₁	a
M22	2.5	118	38	16	12.5
M22X2	2.0	118	38	16	12.5
M22X1.5	1.5	118	38	16	12.5
M22X1	1.0	109	24	16	12.5
M24	3.0	130	45	18	14
M24X2	2.0	130	45	18	14
M24X1.5	1.5	130	45	18	14
M24X1	1.0	114	24	18	14
M27	3.0	135	45	20	16
M27X2	2.0	127	37	20	16
M27X1.5	1.5	127	37	20	16
M27X1	1.0	120	25	20	16

JISSFT

Spiral Flute Machine Tap JIS

HSS-E

<M20

HSS

≥M20

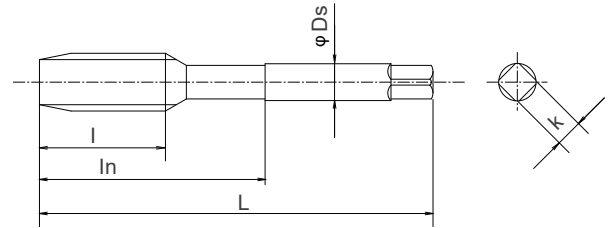
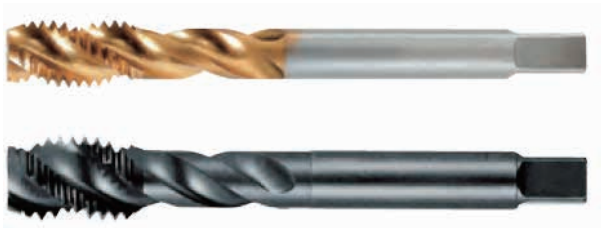

How to Order: JISSFT + Size/ JISSFT + TiN+ Size

Unit: mm

Size	Pitch	L	l	In	Ds	k
M1.4	0.3	34	6		3	2.5
M1.6	0.35	36	7		3	2.5
M2	0.4	40	3.2	10	3	2.5
	0.25	40	3.2	10	3	2.5
M2.2	0.45	42	3.6	11	3	2.5
	0.25	42	3.6	11	3	2.5
M2.5	0.45	44	3.6	13	3	2.5
	0.3	44	3.6	13	3	2.5
M3	0.5	46	4	19	4	3.2
	0.35	46	4	19	4	3.2
M3.5	0.6	48	4.8	20	4	3.2
	0.35	48	4.8	20	4	3.2
M4	0.7	52	5.6	21	5	4
	0.5	52	5.6	21	5	4
M4.5	0.75	55	6	21	5	4
	0.5	55	6	21	5	4
M5	0.8	60	6.4	24	5.5	4.5
	0.5	60	6.4	24	5.5	4.5
M5.5	0.5	60	7.2	25	5.5	4.5
M6	1	62	8	29	6	4.5
	0.75	62	8	29	6	4.5
	0.5	62	8	29	6	4.5
M7	1	65	12	33	6.2	5
	0.75	65	9	33	6.2	5
M8	1.25	70	15	37	6.2	5
	0.5	70	12	37	6.2	5
	0.75	70	12	37	6.2	5
	1	70	12	37	6.2	5

Size	Pitch	L	I	In	Ds	k
M9	1.25	72	15	38	7	5.5
	0.75	72	12	38	7	5.5
	1	72	12	38	7	5.5
M10	1.5	75	18	41	7	5.5
	0.75	75	15	41	7	5.5
	1	75	15	41	7	5.5
	1.25	75	15	41	7	5.5
M11	1.5	80	18	48	8	6
	0.75	80	15	48	8	6
	1	80	15	48	8	6
M12	1.75	82	21	48	8.5	6.5
	1	82	18	48	8.5	6.5
	1.25	82	18	48	8.5	6.5
	1.5	82	18	48	8.5	6.5
M14	2	88	24	48	10.5	8
	1	88	18	48	10.5	8
	1.25	88	18	48	10.5	8
	1.5	88	18	48	10.5	8
M16	2	95	24	52	12.5	10
	1	95	18	52	12.5	10
	1.5	95	18	52	12.5	10
M18	2.5	100	30	55	14	11
	1	100	24	55	14	11
	1.5	100	24	55	14	11
	2	100	24	55	14	11
M20	2.5	105	30	58	15	12
	1	105	24	58	15	12
	1.5	105	24	58	15	12
	2	105	24	58	15	12
M22	2.5	115	30	63	17	13
	1	115	24	63	17	13
	1.5	115	24	63	17	13
	2	115	24	63	17	13
M24	3	120	36	66	19	15
	1	120	24	66	19	15
	1.5	120	24	66	19	15
	2	120	24	66	19	15
M27	3	160	36	71	20	15
	1.5	140	24	79	20	15
M30	3.5	180	42	74	23	17
M33	3.5	180	42	77	25	19
M36	4	200	48	82	28	21

JISSPPT

Spiral Point Tap JIS

HSS-E HSS
 <M20 ≥M20

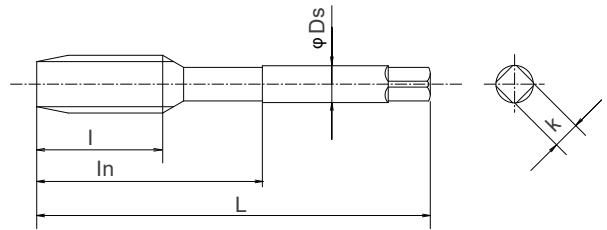

How to Order: JISSPPT + Size/ JISSPPT+TiN+ Size

Unit: mm

Size	Pitch	L	l	In	Ds	k
M1.4	0.3	34	9		3	2.5
M1.6	0.35	36	10		3	2.5
M2	0.4	40	12	10	3	2.5
	0.25	40	12	10	3	
M2.2	0.45	42	13	11	3	2.5
	0.25	42	13	11	3	
M2.5	0.45	44	14	13	3	2.5
	0.3	44	14	13	3	
M3	0.5	46	11	19	4	3.2
	0.35	46	11	19	4	3.2
M3.5	0.6	48	13	20	4	3.2
	0.35	48	13	20	4	3.2
M4	0.7	52	13	21	5	4
	0.5	52	13	21	5	4
M4.5	0.75	55	13	21	5	4
	0.5	55	13	21	5	4
M5	0.8	60	16	24	5.5	4.5
	0.5	60	16	24	5.5	4.5
M5.5	0.5	60	17	25	5.5	4.5
M6	1	62	19	29	6	4.5
	0.75	62	19	29	6	4.5
	0.5	62	19	29	6	4.5
M7	1	65	19	33	6.2	5
	0.75	65	19	33	6.2	5
M8	1.25	70	22	37	6.2	5
	0.5	70	22	37	6.2	5
	0.75	70	22	37	6.2	5
	1	70	22	37	6.2	5

Size	Pitch	L	I	In	Ds	k
M9	1.25	72	22	38	7	5.5
	0.75	72	22	38	7	5.5
	1	72	22	38	7	5.5
M10	1.5	75	24	41	7	5.5
	0.75	75	24	41	7	5.5
	1	75	24	41	7	5.5
	1.25	75	24	41	7	5.5
M11	1.5	80	25	48	8	6
	0.75	80	25	48	8	6
	1	80	25	48	8	6
M12	1.75	82	29	48	8.5	6.5
	1	82	29	48	8.5	6.5
	1.25	82	29	48	8.5	6.5
	1.5	82	29	48	8.5	6.5
M14	2	88	30	48	10.5	8
	1	88	30	48	10.5	8
	1.25	88	30	48	10.5	8
	1.5	88	30	48	10.5	8
M16	2	95	32	52	12.5	10
	1	95	32	52	12.5	10
	1.5	95	32	52	12.5	10
M18	2.5	100	37	55	14	11
	1	100	37	55	14	11
	1.5	100	37	55	14	11
	2	100	37	55	14	11
M20	2.5	105	37	58	15	12
	1	105	37	58	15	12
	1.5	105	37	58	15	12
	2	105	37	58	15	12
M22	2.5	115	38	63	17	13
	1	115	38	63	17	13
	1.5	115	38	63	17	13
	2	115	38	63	17	13
M24	3	120	45	66	19	15
	1	120	45	66	19	15
	1.5	120	45	66	19	15
	2	120	45	66	19	15

DIN371SFT

Spiral Flute Tap DIN 371

HSS-E HSS
 <M20 ≥M20

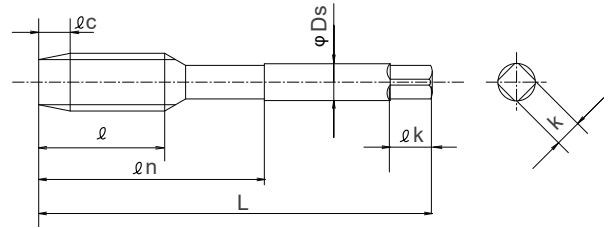
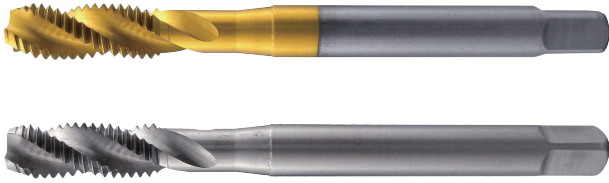

How to Order: DIN371SFT + Size/ DIN371SFT+TiN+ Size

Unit: mm

Size	Pitch	L	l	D _s	k
M2	0.4	45	8	2.8	2.1
M2.2	0.45	45	9	2.8	2.1
M2.3	0.4	45	9	2.8	2.1
M2.5	0.45	50	9	2.8	2.1
M2.6	0.45	50	9	2.8	2.1
M3	0.5	56	11	3.5	2.7
M3.5	0.6	56	13	4	3
M4	0.7	63	13	4.5	3.4
M5	0.8	70	16	6	4.9
M6	1	80	19	6	4.9
M7	1	80	19	7	5.5
M8	1.25	90	22	8	6.2
M9	1.25	90	22	9	7
M10	1.5	100	24	10	8

DIN376SFT

Spiral Flute Tap DIN 376

HSS-E HSS
 <M20 ≥M20

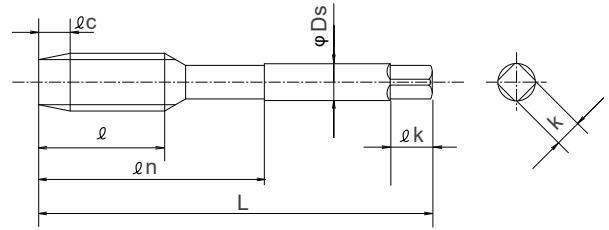
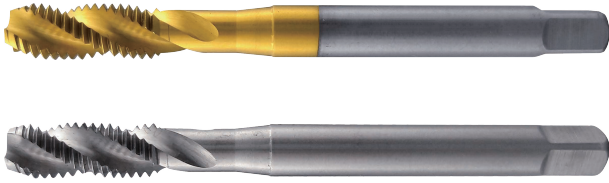

How to Order: DIN376SFT + Size/ DIN376SFT+TiN+ Size

Unit: mm

Size	Pitch	L	l	D _s	k
M3	0.5	56	11	2.2	
M4	0.7	63	13	2.8	2.1
M5	0.8	70	16	3.5	2.7
M6	1	80	19	4.5	3.4
M7	1	80	19	5.5	4.3
M8	1.25	90	22	6	4.9
M9	1.25	90	22	7	5.5
M10	1.5	100	24	7	5.5
M11	1.5	100	24	8	6.2
M12	1.75	110	29	9	7
M14	2	110	30	11	9
M16	2	110	32	12	9
M18	2.5	125	34	14	11
M20	2.5	140	34	16	12
M22	2.5	140	34	18	14.5
M24	3	160	38	18	14.5
M27	3	160	38	20	16
M30	3.5	180	45	22	18
M33	3.5	180	50	25	20
M36	4	200	56	28	22
M39	4	200	60	32	24
M42	4.5	200	60	32	24
M45	4.5	220	65	36	29
M48	5	250	70	36	29
M52	5	250	70	40	32

DIN374SFT

Spiral Flute Tap DIN 374

HSS-E HSS
 <M20 ≥M20

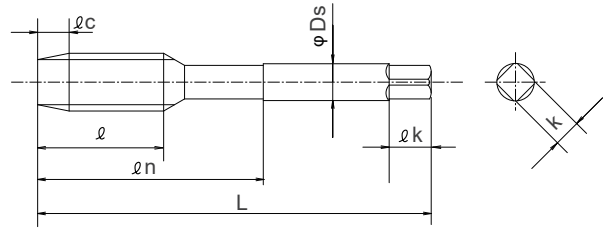
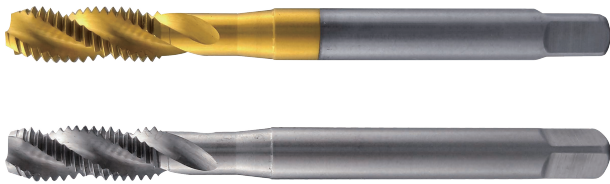

How to Order: DIN374SFT + Size/ DIN374SFT+TiN+ Size

Unit: mm

Size	Pitch	L	l	D _s	k
M3	0.35	56	10	2.2	
M3.5	0.35	56	10	2.5	2.1
M4	0.35	63	10	2.8	2.1
M4	0.5	63	10	2.8	2.1
M5	0.5	70	12	3.5	2.7
M6	0.5	80	14	4.5	3.4
M6	0.75	80	14	4.5	3.4
M7	0.75	80	14	5.5	4.3
M8	0.5	80	19	6.0	4.9
M8	0.75	80	19	6.0	4.9
M8	1	90	22	6.0	4.9
M9	1	90	22	7.0	5.5
M10	0.5	90	20	7.0	5.5
M10	0.75	90	20	7.0	5.5
M10	1	90	20	7.0	5.5
M10	1.25	100	24	7.0	5.5
M11	1	90	20	8.0	6.2
M11	1.25	90	20	8.0	6.2
M12	0.75	100	22	9.0	7
M12	1	100	22	9.0	7
M12	1.25	100	22	9.0	7
M12	1.5	100	22	9.0	7
M13	1	100	22	11.0	9
M13	1.5	100	22	11.0	9
M14	0.75	100	22	11.0	9
M14	1	100	22	11.0	9
M14	1.25	100	22	11.0	9
M14	1.5	100	22	11.0	9

Size	Pitch	L	I	Ds	k
M16	1	100	22	12.0	9
M16	1.25	100	22	12.0	9
M16	1.5	100	22	12.0	9
M18	1	110	25	14.0	11
M18	1.5	110	25	14.0	11
M18	2	125	34	14.0	11
M20	1	125	25	16.0	12
M20	1.5	125	25	16.0	12
M20	2	140	34	16.0	12
M22	1	125	25	18.0	14.5
M22	1.5	125	25	18.0	14.5
M22	2	140	34	18.0	14.5
M24	1	140	28	18.0	14.5
M24	1.5	140	28	18.0	14.5
M24	2	140	28	18.0	14.5
M26	1.5	140	28	18.0	14.5
M27	2	140	28	20.0	16
M27	1.5	140	28	20.0	16
M28	1.5	140	28	20.0	16
M30	2	150	28	22.0	18
M30	1.5	150	28	22.0	18
M32	1.5	150	28	22.0	18
M33	2	160	30	25.0	20
M33	1.5	160	30	25.0	20
M35	1.5	170	30	28.0	22
M36	2	170	30	28.0	22
M36	1.5	170	30	28.0	22
M38	1.5	170	30	28.0	22
M39	1.5	170	30	32.0	24
M40	1.5	170	30	32.0	24
M42	1.5	180	30	32.0	29
M45	1.5	180	32	36.0	29
M48	1.5	190	32	36.0	29
M50	1.5	190	32	36.0	29

DIN371SPPT

Spiral Point Tap DIN 371

HSS-E HSS
 <M20 ≥M20

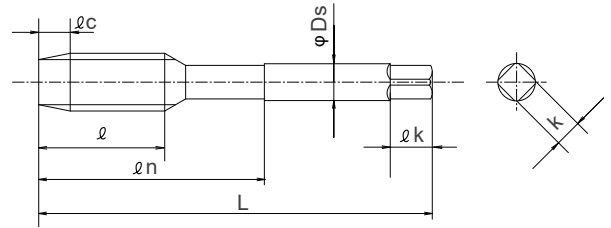

How to Order: DIN371SPPT + Size/ DIN371SPPT+TiN+ Size

Unit: mm

Size	Pitch	L	l	D _s	k
M2	0.4	45	8	2.8	2.1
M2.2	0.45	45	9	2.8	2.1
M2.5	0.45	50	9	2.8	2.1
M3	0.5	56	11	3.5	2.7
M3.5	0.6	56	13	4	3
M4	0.7	63	13	4.5	3.4
M5	0.8	70	16	6	4.9
M6	1	80	19	6	4.9
M7	1	80	19	7	5.5
M8	1.25	90	22	8	6.2
M9	1.25	90	22	9	7
M10	1.25	100	24	10	8

DIN376SPPT

Spiral Point Tap DIN 376

HSS-E HSS
 <M20 ≥M20

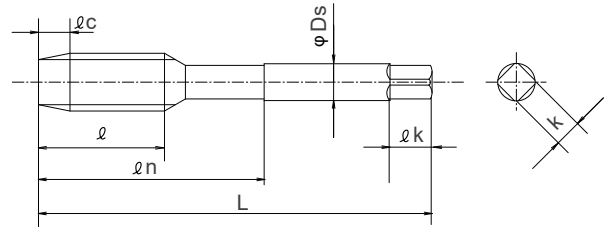

How to Order: DIN376SPPT + Size/ DIN376SPPT+TiN+ Size

Unit: mm

Size	Pitch	L	l	Ds	k
M3	0.5	56	11	2.2	
M4	0.7	63	13	2.8	2.1
M5	0.8	70	16	3.5	2.7
M6	1	80	19	4.5	3.4
M7	1	80	19	5.5	4.3
M8	1.25	90	22	6	4.9
M9	1.25	90	22	7	5.5
M10	1.5	100	24	7	5.5
M11	1.5	100	24	8	6.2
M12	1.75	110	29	9	7
M14	2	110	30	11	9
M16	2	110	32	12	9
M18	2.5	125	34	14	11
M20	2.5	140	34	16	12
M22	2.5	140	34	18	14.5
M24	3	160	38	18	14.5
M27	3	160	38	20	16
M30	3.5	180	45	22	18
M33	3.5	180	50	25	20
M36	4	200	56	28	22
M39	4	200	60	32	24
M42	4.5	200	60	32	24
M45	4.5	220	65	36	29
M48	5	250	70	36	29
M52	5	250	70	40	32

DIN374SPPT

Spiral Point Tap DIN374

HSS-E HSS
 <M20 ≥M20

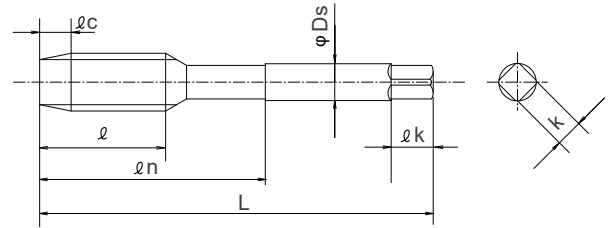

How to Order: DIN374SPPT + Size/ DIN374SPPT+TiN+ Size

Unit: mm

Size	Pitch	L	l	D _s	k
M3	0.35	56	10	2.2	
M3.5	0.35	56	10	2.5	2.1
M4	0.35	63	10	2.8	2.1
M4	0.5	63	10	2.8	2.1
M5	0.5	70	12	3.5	2.7
M6	0.5	80	14	4.5	3.4
M6	0.75	80	14	4.5	3.4
M7	0.75	80	14	5.5	4.3
M8	0.5	80	19	6.0	4.9
M8	0.75	80	19	6.0	4.9
M8	1	90	22	6.0	4.9
M9	1	90	22	7.0	5.5
M10	0.5	90	20	7.0	5.5
M10	0.75	90	20	7.0	5.5
M10	1	90	20	7.0	5.5
M10	1.25	100	24	7.0	5.5
M11	1	90	20	8.0	6.2
M11	1.25	90	20	8.0	6.2
M12	0.75	100	22	9.0	7
M12	1	100	22	9.0	7
M12	1.25	100	22	9.0	7
M12	1.5	100	22	9.0	7
M13	1	100	22	11.0	9
M13	1.5	100	22	11.0	9
M14	0.75	100	22	11.0	9
M14	1	100	22	11.0	9
M14	1.25	100	22	11.0	9
M14	1.5	100	22	11.0	9

Size	Pitch	L	I	Ds	k
M16	1	100	22	12.0	9
M16	1.25	100	22	12.0	9
M16	1.5	100	22	12.0	9
M18	1	110	25	14.0	11
M18	1.5	110	25	14.0	11
M18	2	125	34	14.0	11
M20	1	125	25	16.0	12
M20	1.5	125	25	16.0	12
M20	2	140	34	16.0	12
M22	1	125	25	18.0	14.5
M22	1.5	125	25	18.0	14.5
M22	2	140	34	18.0	14.5
M24	1	140	28	18.0	14.5
M24	1.5	140	28	18.0	14.5
M24	2	140	28	18.0	14.5
M26	1.5	140	28	18.0	14.5
M27	2	140	28	20.0	16
M27	1.5	140	28	20.0	16
M28	1.5	140	28	20.0	16
M30	2	150	28	22.0	18
M30	1.5	150	28	22.0	18
M32	1.5	150	28	22.0	18
M33	2	160	30	25.0	20
M33	1.5	160	30	25.0	20
M35	1.5	170	30	28.0	22
M36	2	170	30	28.0	22
M36	1.5	170	30	28.0	22
M38	1.5	170	30	28.0	22
M39	1.5	170	30	32.0	24
M40	1.5	170	30	32.0	24
M42	1.5	180	30	32.0	29
M45	1.5	180	32	36.0	29
M48	1.5	190	32	36.0	29
M50	1.5	190	32	36.0	29

PT

55°(ZG) Taper Pipe Tap PT

HSS

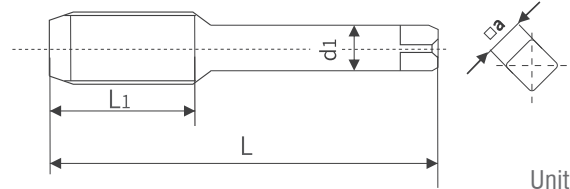

How to Order: PT + Size

Unit: mm

Size	L	L1	d1	a
ZG1/8	55	18	9	7
ZG1/4	60	22	11	9
ZG3/8	70	24	14	11
ZG1/2	75	28	18	15
ZG3/4	80	30	22	18
Zg1	95	36	26	20
ZG11/4	105	38	34	26
ZG11/2	110	40	38	29
ZG2	120	42	52	39

NPT

60°(Z) Taper Pipe Tap NPT

HSS

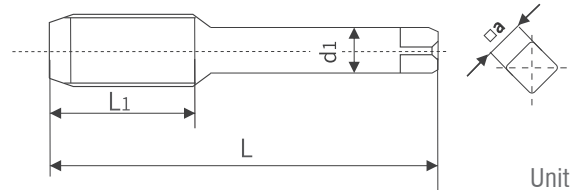

How to Order: NPT + Size

Unit: mm

Size	L	L1	d1	a
NPT1/8	55	16	9	7
NPT1/4	60	20	11	9
NPT3/8	70	22	14	11
NPT1/2	75	28	18	15
NPT3/4	80	28	22	18
NPT1	95	34	26	20
NPT11/4	105	35	34	26
NPT1/2	110	35	38	29
NPT2	120	36	52	39

G

55°(G) Cylindrical Pipe Tap

HSS

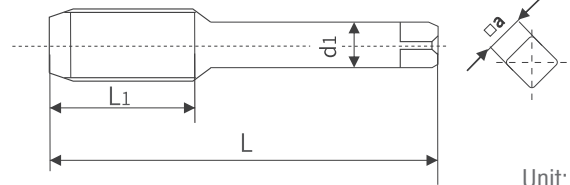
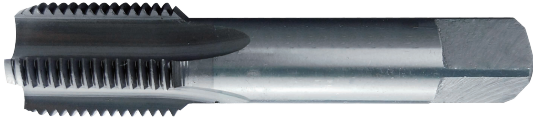

How to Order: G + Size

Unit: mm

Size	L	L1	d1	a
G1/8	55	18	8.0	6.3
G1/4	65	24	10.0	8
G3/8	70	26	12.5	10
G1/2	80	30	16.0	12.5
G3/4	80	30	18.0	14
G1	95	40	25	20
G1 1/4	105	40	31.5	25
G1 1/2	105	40	35.5	28
G2	115	45	40	31.5

UN

UNC/UNF Tap

HSS

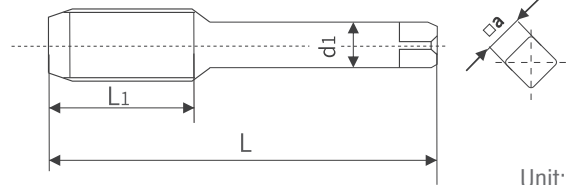

How to Order: UN + Size

Unit: mm

Size	a	d1	L1	L
5/16-18UNC	5	6.3	20	72
5/16-24UNF			17	72
5/16-32UNF			17	66
3/8-16UNC	6.3	8	22	80
3/8-24UNF			18	80
3/8-32UNEF			18	72
7/16-14UNC			22	85
7/16-20UNF			22	85
7/16-28UNEF	22	80		
1/2-13UNC	7.1	9	29	89
1/2-16UN			29	89
1/2-20UNF			29	89
1/2-28UNEF			20	80
1/2-32UN			20	80
9/16-12UNC	9	11.2	26	95
9/16-16UN			26	95
9/16-18UNF			22	95
9/16-24UNEF			18	90
9/16-32UN			16	90
5/8-11UNC	10	12.5	27	102
5/8-12UN			27	102
5/8-16UN			25	102
5/8-18UNF			25	102
5/8-20UN			25	102
5/8-24UNEF			18	92
5/8-28UN			18	92
5/8-32UN			16	92

Size	a	d1	L1	L
11/16-12UN	11.2	14	27	112
11/16-16UN			25	112
11/16-20UN			25	112
11/16-24UNEF			18	97
11/16-28UN			18	97
11/16-32UN			18	97
3/4-10UNC			30	112
3/4-12UN			27	112
3/4-16UNF			25	112
3/4-20UNEF			25	112
3/4-28UN			18	102
3/4-32UN			18	102
13/16-12UN			27	112
13/16-16UN			25	112
13/16-20UNEF			25	112
13/16-28UN			17	102
13/16-32UN			17	102
7/8-9UNC			12.5	16
7/8-12UN	27	118		
7/8-14UNF	22	118		
7/8-16UN	27	118		
7/8-20UNEF	25	118		
7/8-28UN	18	109		
7/8-32UN	18	109		
15/16-12UN	14	18	28	130
15/16-16UN			25	130
15/16-20UNEF			25	130
15/16-28UN			18	114
15/16-32UN			18	114
1-8UNC			36	130
1-12UNF			28	130
1-16UN			25	130
1-20UNEF			25	130
1-28UN			18	120
1-32UN	18	120		
1 1/16-8UN	16	20	38	135
1 1/16-12UN			28	127
1 1/16-16UN			25	127
1 1/16-18UNEF			25	127
1 1/16-20UN			25	127
1 1/16-28UN			18	120
1 1/16-7UNC			40	135
1 1/8-8UN			36	130
1 1/8-16UN			25	127
1 1/8-18UNEF			25	127
1 1/8-20UN			25	127

CNC TOOL

60 YEARS FOCUS INNOVATION



3CD

3xD Solid Carbide Twist Drill



Material



Coating



Point Angle



Helix Angle



Diameter Range

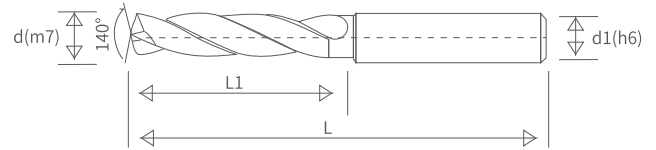
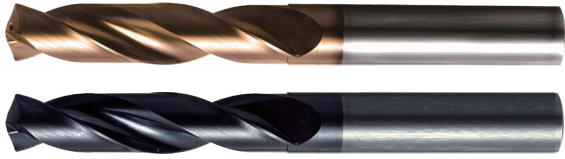

How to Order: 3CD + Size+ Coating+ Coolant or not

Unit: mm

Size:d(m7)	L	L1	d1(h6)
3.0	62	20	6
3.1			
3.2			
3.3			
3.4			
3.5			
3.6			
3.7			
3.8	66	24	
3.9			
4.0			
4.1			
4.2			
4.3			
4.4			
4.5			
4.6			
4.7			
4.8	66	28	
4.9			
5.0			
5.1			
5.2			
5.3			
5.4			
5.5			
5.6			
5.7			
5.8			
5.9			
6.0			
6.1	79	34	8
6.2			
6.3			
6.4			

Size:d(m7)	L	L1	d1(h6)
6.5	79	34	8
6.6			
6.7			
6.8			
6.9			
7.0			
7.1			
7.2			
7.3	79	41	
7.4			
7.5			
7.6			
7.7			
7.8			
7.9			
8.0			
8.1	89	47	10
8.2			
8.3			
8.4			
8.5			
8.6			
8.7			
8.8			
8.9			
9.0			
9.1			
9.2			
9.3			
9.4			
9.5			
9.6			
9.7			
9.8			
9.9			

Size:d(m7)	L	L1	d1(h6)
10.0	89	47	10
10.1	102	55	12
10.2			
10.3			
10.4			
10.5			
10.6			
10.7			
10.8			
10.9			
11.0			
11.1			
11.2			
11.3			
11.4			
11.5			
11.6			
11.7			
11.8			
11.9			
12.0			
12.1	107	60	14
12.2			
12.3			
12.4			
12.5			
12.6			
12.7			
12.8			
12.9			
13.0			
13.1			
13.2			
13.3			
13.4			
13.5			
13.6			
14.0			
14.1	115	65	16
14.2			
14.3			
14.4			
14.5			

Size:d(m7)	L	L1	d1(h6)
14.6	115	65	16
14.7			
14.8			
14.9			
15.0			
15.1			
15.2			
15.3			
15.4			
15.5			
15.6			
15.7			
15.8			
15.9			
16.0			
16.1	123	73	18
16.2			
16.3			
16.4			
16.5			
16.6			
16.7			
16.8			
16.9			
17.0			
17.1			
17.2			
17.3			
17.4			
17.5			
17.6			
17.7			
17.8			
17.9			
18.0			
18.1-19.0	131	79	20
19.1-20.0			
-	-	-	-

5CD

5xD Solid Carbide Twist Drill



Material



Coating



Point Angle



Helix Angle



Diameter Range

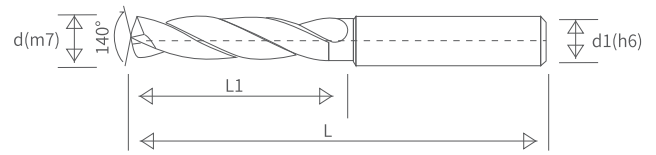
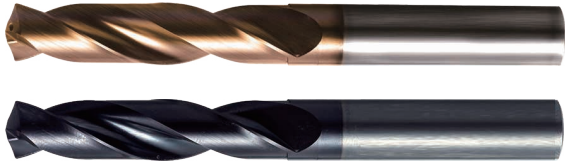

How to Order: 5CD + Size+ Coating+ Coolant or not

Unit: mm

Size:d(m7)	L	L1	d1(h6)
3.0	66	28	6
3.1			
3.2			
3.3			
3.4			
3.5			
3.6			
3.7			
3.8	74	36	
3.9			
4.0			
4.1			
4.2			
4.3			
4.4			
4.5			
4.6			
4.7			
4.8	82	44	
4.9			
5.0			
5.1			
5.2			
5.3			
5.4			
5.5			
5.6			
5.7			
5.8			
5.9			
6.0			
6.1	91	53	8
6.2			
6.3			
6.4			

Size:d(m7)	L	L1	d1(h6)
6.5	91	53	8
6.6			
6.7			
6.8			
6.9			
7.0			
7.1			
7.2			
7.3			
7.4			
7.5			
7.6			
7.7			
7.8			
7.9			
8.0	103	61	10
8.1			
8.2			
8.3			
8.4			
8.5			
8.6			
8.7			
8.8			
8.9			
9.0			
9.1			
9.2			
9.3			
9.4			
9.5			
9.6			
9.7			
9.8			
9.9			

Size:d(m7)	L	L1	d1(h6)
10.0	103	61	10
10.1	118	71	12
10.2			
10.3			
10.4			
10.5			
10.6			
10.7			
10.8			
10.9			
11.0			
11.1			
11.2			
11.3			
11.4			
11.5			
11.6			
11.7			
11.8			
11.9			
12.0			
12.1	124	77	14
12.2			
12.3			
12.4			
12.5			
12.6			
12.7			
12.8			
12.9			
13.0			
13.1			
13.2			
13.3			
13.4			
13.5			
13.6			
14.0			
14.1	133	83	16
14.2			
14.3			
14.4			
14.5			

Size:d(m7)	L	L1	d1(h6)
14.6	133	83	16
14.7			
14.8			
14.9			
15.0			
15.1			
15.2			
15.3			
15.4			
15.5			
15.6			
15.7			
15.8			
15.9			
16.0			
16.1	143	93	18
16.2			
16.3			
16.4			
16.5			
16.6			
16.7			
16.8			
16.9			
17.0			
17.1			
17.2			
17.3			
17.4			
17.5			
17.6			
17.7			
17.8			
17.9			
18.0			
18.1-19.0	153	101	20
19.1-20.0			

3CDSS

3xD Solid Carbide Twist Drill for Stainless Steel



Material



Coating



Point Angle



Helix Angle



Diameter Range

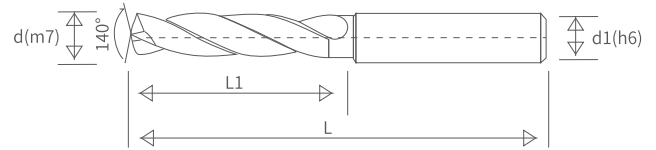
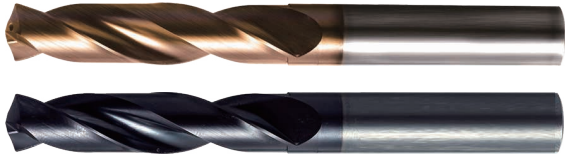

How to Order: 3CDSS + Size+ Coating+ Coolant or not

Unit: mm

Size:d(m7)	L	L1	d1(h6)
3.0	62	20	6
3.1			
3.2			
3.3			
3.4			
3.5			
3.6			
3.7			
3.8	66	24	
3.9			
4.0			
4.1			
4.2			
4.3			
4.4			
4.5			
4.6			
4.7			
4.8	66	28	
4.9			
5.0			
5.1			
5.2			
5.3			
5.4			
5.5			
5.6			
5.7			
5.8			
5.9			
6.0			
6.1	79	34	8
6.2			
6.3			
6.4			

Size:d(m7)	L	L1	d1(h6)
6.5	79	34	8
6.6			
6.7			
6.8			
6.9			
7.0			
7.1			
7.2			
7.3	79	41	
7.4			
7.5			
7.6			
7.7			
7.8			
7.9			
8.0			
8.1	89	47	10
8.2			
8.3			
8.4			
8.5			
8.6			
8.7			
8.8			
8.9			
9.0			
9.1			
9.2			
9.3			
9.4			
9.5			
9.6			
9.7			
9.8			
9.9			

Size:d(m7)	L	L1	d1(h6)
10.0	89	47	10
10.1	102	55	12
10.2			
10.3			
10.4			
10.5			
10.6			
10.7			
10.8			
10.9			
11.0			
11.1			
11.2			
11.3			
11.4			
11.5			
11.6			
11.7			
11.8			
11.9			
12.0			
12.1	107	60	14
12.2			
12.3			
12.4			
12.5			
12.6			
12.7			
12.8			
12.9			
13.0			
13.1			
13.2			
13.3			
13.4			
13.5			
13.6			
14.0			
14.1	115	65	16
14.2			
14.3			
14.4			
14.5			

Size:d(m7)	L	L1	d1(h6)
14.6	115	65	16
14.7			
14.8			
14.9			
15.0			
15.1			
15.2			
15.3			
15.4			
15.5			
15.6			
15.7			
15.8			
15.9			
16.0			
16.1	123	73	18
16.2			
16.3			
16.4			
16.5			
16.6			
16.7			
16.8			
16.9			
17.0			
17.1			
17.2			
17.3			
17.4			
17.5			
17.6			
17.7			
17.8			
17.9			
18.0			
18.1-19.0	131	79	20
19.1-20.0			
-	-	-	-

5CDSS

5xD Solid Carbide Twist Drill for Stainless Steel



Material



Coating



Point Angle



Helix Angle



Diameter Range

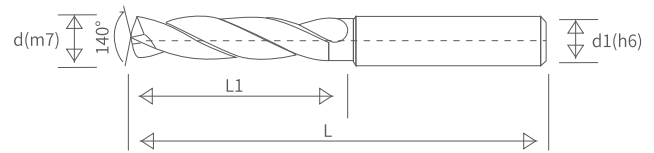
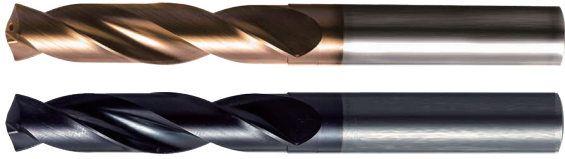

How to Order: 5CDSS + Size+ Coating+ Coolant or not

Unit: mm

Size:d(m7)	L	L1	d1(h6)
3.0	66	28	6
3.1			
3.2			
3.3			
3.4			
3.5			
3.6			
3.7			
3.8	74	36	
3.9			
4.0			
4.1			
4.2			
4.3			
4.4			
4.5			
4.6			
4.7			
4.8	82	44	
4.9			
5.0			
5.1			
5.2			
5.3			
5.4			
5.5			
5.6			
5.7			
5.8			
5.9			
6.0			
6.1	91	53	8
6.2			
6.3			
6.4			

Size:d(m7)	L	L1	d1(h6)
6.5	91	53	8
6.6			
6.7			
6.8			
6.9			
7.0			
7.1			
7.2			
7.3			
7.4			
7.5			
7.6			
7.7			
7.8			
7.9			
8.0	103	61	10
8.1			
8.2			
8.3			
8.4			
8.5			
8.6			
8.7			
8.8			
8.9			
9.0			
9.1			
9.2			
9.3			
9.4			
9.5			
9.6			
9.7			
9.8			
9.9			

Size:d(m7)	L	L1	d1(h6)
10.0	103	61	10
10.1	118	71	12
10.2			
10.3			
10.4			
10.5			
10.6			
10.7			
10.8			
10.9			
11.0			
11.1			
11.2			
11.3			
11.4			
11.5			
11.6			
11.7			
11.8			
11.9			
12.0			
12.1	124	77	14
12.2			
12.3			
12.4			
12.5			
12.6			
12.7			
12.8			
12.9			
13.0			
13.1			
13.2			
13.3			
13.4			
13.5			
13.6			
14.0			
14.1	133	83	16
14.2			
14.3			
14.4			
14.5			

Size:d(m7)	L	L1	d1(h6)
14.6	133	83	16
14.7			
14.8			
14.9			
15.0			
15.1			
15.2			
15.3			
15.4			
15.5			
15.6			
15.7			
15.8			
15.9			
16.0			
16.1	143	93	18
16.2			
16.3			
16.4			
16.5			
16.6			
16.7			
16.8			
16.9			
17.0			
17.1			
17.2			
17.3			
17.4			
17.5			
17.6			
17.7			
17.8			
17.9			
18.0			
18.1-19.0	153	101	20
19.1-20.0			

3HCD

3xD High Hardness Solid Carbide Twist Drill



Material



Coating



Point Angle



Helix Angle



Diameter Range

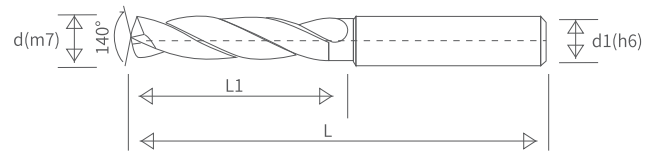
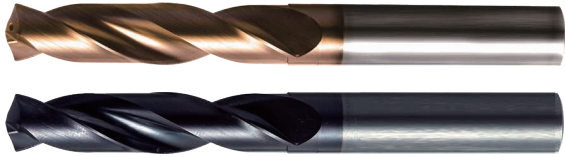

How to Order: 3HCD + Size+ Coating+ Coolant or not

Unit: mm

Size:d(m7)	L	L1	d1(h6)
3.0	62	20	6
3.1			
3.2			
3.3			
3.4			
3.5			
3.6			
3.7			
3.8	66	24	
3.9			
4.0			
4.1			
4.2			
4.3			
4.4			
4.5			
4.6			
4.7			
4.8	66	28	
4.9			
5.0			
5.1			
5.2			
5.3			
5.4			
5.5			
5.6			
5.7			
5.8			
5.9			
6.0			
6.1	79	34	8
6.2			
6.3			
6.4			

Size:d(m7)	L	L1	d1(h6)
6.5	79	34	8
6.6			
6.7			
6.8			
6.9			
7.0			
7.1			
7.2			
7.3	79	41	
7.4			
7.5			
7.6			
7.7			
7.8			
7.9			
8.0			
8.1	89	47	10
8.2			
8.3			
8.4			
8.5			
8.6			
8.7			
8.8			
8.9			
9.0			
9.1			
9.2			
9.3			
9.4			
9.5			
9.6			
9.7			
9.8			
9.9			

Size:d(m7)	L	L1	d1(h6)
10.0	89	47	10
10.1	102	55	12
10.2			
10.3			
10.4			
10.5			
10.6			
10.7			
10.8			
10.9			
11.0			
11.1			
11.2			
11.3			
11.4			
11.5			
11.6			
11.7			
11.8			
11.9			
12.0			
12.1	107	60	14
12.2			
12.3			
12.4			
12.5			
12.6			
12.7			
12.8			
12.9			
13.0			
13.1			
13.2			
13.3			
13.4			
13.5			
13.6			
14.0			
14.1	115	65	16
14.2			
14.3			
14.4			
14.5			

Size:d(m7)	L	L1	d1(h6)
14.6	115	65	16
14.7			
14.8			
14.9			
15.0			
15.1			
15.2			
15.3			
15.4			
15.5			
15.6			
15.7			
15.8			
15.9			
16.0			
16.1	123	73	18
16.2			
16.3			
16.4			
16.5			
16.6			
16.7			
16.8			
16.9			
17.0			
17.1			
17.2			
17.3			
17.4			
17.5			
17.6			
17.7			
17.8			
17.9			
18.0			
18.1-19.0	131	79	20
19.1-20.0			
-	-	-	-

5HCD

5xD High Hardness Solid Carbide Twist Drill



Material



Coating



Point Angle



Helix Angle



Diameter Range

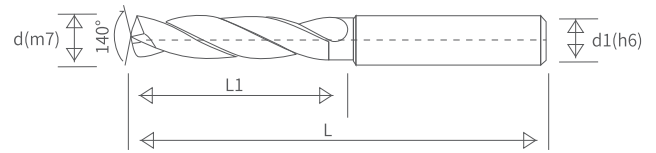
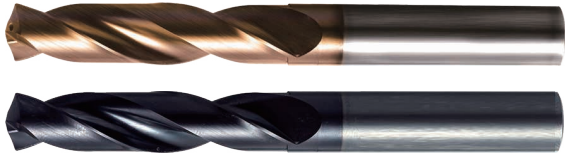

How to Order: 5HCD+ Size+ Coating+ Coolant or not

Unit: mm

Size:d(m7)	L	L1	d1(h6)
3.0	66	28	6
3.1			
3.2			
3.3			
3.4			
3.5			
3.6			
3.7			
3.8	74	36	
3.9			
4.0			
4.1			
4.2			
4.3			
4.4			
4.5			
4.6			
4.7			
4.8	82	44	
4.9			
5.0			
5.1			
5.2			
5.3			
5.4			
5.5			
5.6			
5.7			
5.8			
5.9			
6.0			
6.1	91	53	8
6.2			
6.3			
6.4			

Size:d(m7)	L	L1	d1(h6)
6.5	91	53	8
6.6			
6.7			
6.8			
6.9			
7.0			
7.1			
7.2			
7.3			
7.4			
7.5			
7.6			
7.7			
7.8			
7.9			
8.0			
8.1	103	61	10
8.2			
8.3			
8.4			
8.5			
8.6			
8.7			
8.8			
8.9			
9.0			
9.1			
9.2			
9.3			
9.4			
9.5			
9.6			
9.7			
9.8			
9.9			

Size:d(m7)	L	L1	d1(h6)
10.0	103	61	10
10.1	118	71	12
10.2			
10.3			
10.4			
10.5			
10.6			
10.7			
10.8			
10.9			
11.0			
11.1			
11.2			
11.3			
11.4			
11.5			
11.6			
11.7			
11.8			
11.9			
12.0			
12.1	124	77	14
12.2			
12.3			
12.4			
12.5			
12.6			
12.7			
12.8			
12.9			
13.0			
13.1			
13.2			
13.3			
13.4			
13.5			
13.6			
14.0			
14.1	133	83	16
14.2			
14.3			
14.4			
14.5			

Size:d(m7)	L	L1	d1(h6)
14.6	133	83	16
14.7			
14.8			
14.9			
15.0			
15.1			
15.2			
15.3			
15.4			
15.5			
15.6			
15.7			
15.8			
15.9			
16.0			
16.1	143	93	18
16.2			
16.3			
16.4			
16.5			
16.6			
16.7			
16.8			
16.9			
17.0			
17.1			
17.2			
17.3			
17.4			
17.5			
17.6			
17.7			
17.8			
17.9			
18.0			
18.1-19.0	153	101	20
19.1-20.0			

3CDA

3xD Solid Carbide Twist Drill for Aluminum



Material



Coating



Point Angle



Helix Angle



Diameter Range

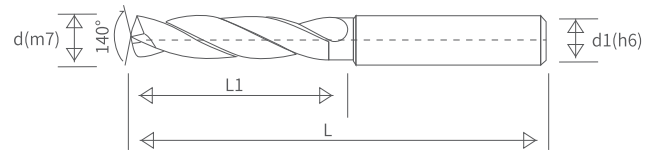
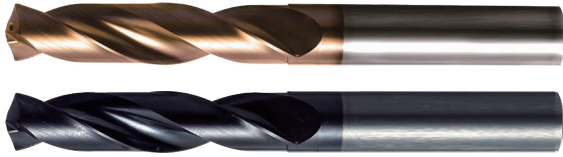

How to Order: 3CDA + Size+ Coating+ Coolant or not

Unit: mm

Size:d(m7)	L	L1	d1(h6)
3.0	62	20	6
3.1			
3.2			
3.3			
3.4			
3.5			
3.6			
3.7			
3.8	66	24	
3.9			
4.0			
4.1			
4.2			
4.3			
4.4			
4.5			
4.6			
4.7			
4.8	66	28	
4.9			
5.0			
5.1			
5.2			
5.3			
5.4			
5.5			
5.6			
5.7			
5.8			
5.9			
6.0			
6.1	79	34	8
6.2			
6.3			
6.4			

Size:d(m7)	L	L1	d1(h6)
6.5	79	34	8
6.6			
6.7			
6.8			
6.9			
7.0			
7.1			
7.2			
7.3	79	41	
7.4			
7.5			
7.6			
7.7			
7.8			
7.9			
8.0			
8.1	89	47	10
8.2			
8.3			
8.4			
8.5			
8.6			
8.7			
8.8			
8.9			
9.0			
9.1			
9.2			
9.3			
9.4			
9.5			
9.6			
9.7			
9.8			
9.9			

Size:d(m7)	L	L1	d1(h6)
10.0	89	47	10
10.1	102	55	12
10.2			
10.3			
10.4			
10.5			
10.6			
10.7			
10.8			
10.9			
11.0			
11.1			
11.2			
11.3			
11.4			
11.5			
11.6			
11.7			
11.8			
11.9			
12.0			
12.1	107	60	14
12.2			
12.3			
12.4			
12.5			
12.6			
12.7			
12.8			
12.9			
13.0			
13.1			
13.2			
13.3			
13.4			
13.5			
13.6			
14.0			
14.1	115	65	16
14.2			
14.3			
14.4			
14.5			

Size:d(m7)	L	L1	d1(h6)
14.6	115	65	16
14.7			
14.8			
14.9			
15.0			
15.1			
15.2			
15.3			
15.4			
15.5			
15.6			
15.7			
15.8			
15.9			
16.0			
16.1	123	73	18
16.2			
16.3			
16.4			
16.5			
16.6			
16.7			
16.8			
16.9			
17.0			
17.1			
17.2			
17.3			
17.4			
17.5			
17.6			
17.7			
17.8			
17.9			
18.0			
18.1-19.0	131	79	20
19.1-20.0			
-	-	-	-

5CDA

5xD Solid Carbide Twist Drill for Aluminum



Material



Coating



Point Angle



Helix Angle



Diameter Range

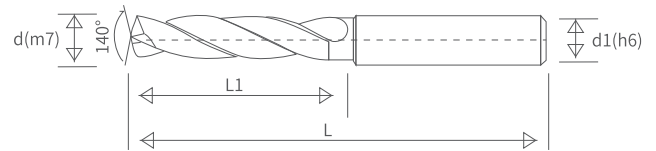
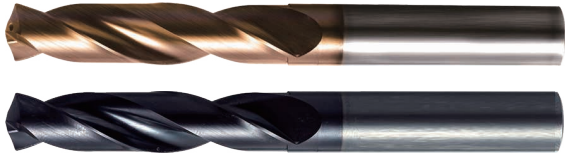

How to Order: 5CDA + Size/ 5CDA + Size + Coating

Unit: mm

Size:d(m7)	L	L1	d1(h6)
3.0	66	28	6
3.1			
3.2			
3.3			
3.4			
3.5			
3.6			
3.7			
3.8	74	36	
3.9			
4.0			
4.1			
4.2			
4.3			
4.4			
4.5			
4.6			
4.7			
4.8	82	44	
4.9			
5.0			
5.1			
5.2			
5.3			
5.4			
5.5			
5.6			
5.7			
5.8			
5.9			
6.0			
6.1	91	53	8
6.2			
6.3			
6.4			

Size:d(m7)	L	L1	d1(h6)
6.5	91	53	8
6.6			
6.7			
6.8			
6.9			
7.0			
7.1			
7.2			
7.3			
7.4			
7.5			
7.6			
7.7			
7.8			
7.9			
8.0			
8.1	103	61	10
8.2			
8.3			
8.4			
8.5			
8.6			
8.7			
8.8			
8.9			
9.0			
9.1			
9.2			
9.3			
9.4			
9.5			
9.6			
9.7			
9.8			
9.9			

Size:d(m7)	L	L1	d1(h6)
10.0	103	61	10
10.1	118	71	12
10.2			
10.3			
10.4			
10.5			
10.6			
10.7			
10.8			
10.9			
11.0			
11.1			
11.2			
11.3			
11.4			
11.5			
11.6			
11.7			
11.8			
11.9			
12.0			
12.1	124	77	14
12.2			
12.3			
12.4			
12.5			
12.6			
12.7			
12.8			
12.9			
13.0			
13.1			
13.2			
13.3			
13.4			
13.5			
13.6			
14.0			
14.1	133	83	16
14.2			
14.3			
14.4			
14.5			

Size:d(m7)	L	L1	d1(h6)
14.6	133	83	16
14.7			
14.8			
14.9			
15.0			
15.1			
15.2			
15.3			
15.4			
15.5			
15.6			
15.7			
15.8			
15.9			
16.0			
16.1	143	93	18
16.2			
16.3			
16.4			
16.5			
16.6			
16.7			
16.8			
16.9			
17.0			
17.1			
17.2			
17.3			
17.4			
17.5			
17.6			
17.7			
17.8			
17.9			
18.0			
18.1-19.0	153	101	20
19.1-20.0			

2DWC

2xD WC Type Indexable Drill

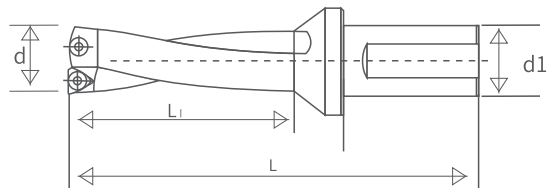

How to Order: 2DWC+ Size

Unit: mm

Size(d)	L	L1	d1 (h6)	Suitable Insert
16.0	106	35	20/25	WCMX 030208
16.5	107	36		
17.0	108	37		
17.5	109	38		
18.0	110	39		
18.5	111	40		
19.0	112	41		
19.5	113	42		
20.0	114	43		
20.5	115	44		
21.0	116	45	25	WCMX 040208
21.5	117	46		
22.0	118	47		
22.5	119	48		
23.0	123	49		
23.5	124	50		
24.0	125	51		
24.5	126	52		
25.0	127	53		
25.5	134	54		
26.0	135	55	32	WCMX 050308
26.5	136	56		
27.0	137	57		
27.5	138	58		
28.0	139	59		
28.5	140	60		
29.0	143	62		
29.5	144	63		
30.0	148	64		
30.5	149	65		
31.0	150	66	WCMX 06T308	
31.5	151	67		
32.0	152	68		
32.5	153	69		
33.0	154	70		

Size(d)	L	L1	d1 (h6)	Suitable Insert
33.5	155	71	32	WCMX 06T308
34.0	156	72		
34.5	157	73		
35.0	158	74		
35.5	159	75		
36.0	160	76		
36.5	161	77		
37.0	169	79		
37.5	170	80		
38.0	171	81		
38.5	172	82	40	WCMX 080412
39.0	183	83		
39.5	184	84		
40.0	185	85		
41.0	187	87		
42.0	189	89		
43.0	191	91		
44.0	193	93		
45.0	195	95		
46.0	197	97		
47.0	199	99		
48.0	201	101		
49.0	203	103		
50.0	205	105		
51.0	207	107		
52.0	209	109		
53.0	211	111		
54.0	213	113		
55.0	215	115		
56.0	222	120		
57.0	224	122		
58.0	226	124		
59.0	228	126		
60.0	230	128		
-	-	-		

2DSP

2xD SP Type Indexable Drill

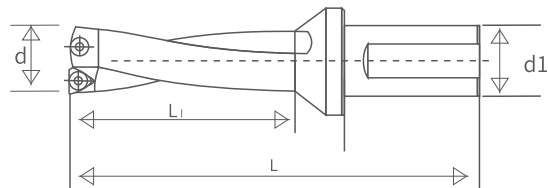

How to Order: 2DSP+ Size

Unit: mm

Size(d)	L	L1	d1 (h6)
16.0	106	35	20/25
16.5	107	36	
17.0	108	37	
17.5	109	38	
18.0	110	39	
18.5	111	40	25
19.0	112	41	
19.5	113	42	
20.0	114	43	
20.5	115	44	
21.0	116	45	
21.5	117	46	
22.0	118	47	
22.5	119	48	
23.0	123	49	
23.5	124	50	32
24.0	125	51	
24.5	126	52	
25.0	127	53	
25.5	134	54	
26.0	135	55	
26.5	136	56	
27.0	137	57	
27.5	138	58	
28.0	139	59	
28.5	140	60	
29.0	143	62	
29.5	144	63	
30.0	148	64	
30.5	149	65	
31.0	150	66	
31.5	151	67	
32.0	152	68	
32.5	153	69	
33.0	154	70	

Size(d)	L	L1	d1 (h6)
33.5	155	71	32
34.0	156	72	
34.5	157	73	
35.0	158	74	
35.5	159	75	
36.0	160	76	
36.5	161	77	
37.0	169	79	
37.5	170	80	
38.0	171	81	
38.5	172	82	
39.0	183	83	
39.5	184	84	
40.0	185	85	
41.0	187	87	
42.0	189	89	
43.0	191	91	40
44.0	193	93	
45.0	195	95	
46.0	197	97	
47.0	199	99	
48.0	201	101	
49.0	203	103	
50.0	205	105	
51.0	207	107	
52.0	209	109	
53.0	211	111	
54.0	213	113	
55.0	215	115	
56.0	222	120	
57.0	224	122	
58.0	226	124	
59.0	228	126	
60.0	230	128	
-	-	-	

3DWC

3xD WC Type Indexable Drill

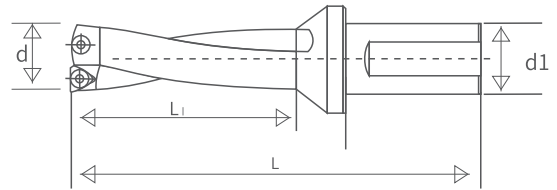

How to Order: 3DWC+ Size

Unit: mm

Size(d)	L	L1	d1 (h6)	Suitable Insert
16.0	122	51	20/25	WCMX 030208
16.5	124	53		
17.0	125	54		
17.5	127	56		
18.0	128	57		
18.5	130	59		
19.0	131	60		
19.5	133	62		
20.0	134	63		
20.5	136	65		
21.0	137	66	25	WCMX 040208
21.5	139	68		
22.0	140	69		
22.5	142	71		
23.0	146	72		
23.5	148	74		
24.0	149	75		
24.5	151	77		
25.0	152	78		
25.5	160	80		
26.0	161	81	32	WCMX 050308
26.5	163	83		
27.0	164	84		
27.5	166	86		
28.0	167	87		
28.5	169	89		
29.0	172	91		
29.5	174	93		
30.0	178	94		
30.5	180	96		
31.0	181	97	WCMX 06T308	
31.5	183	99		
32.0	184	100		
32.5	186	102		
33.0	187	103		

Size(d)	L	L1	d1 (h6)	Suitable Insert
33.5	189	105	32	WCMX 06T308
34.0	190	106		
34.5	192	108		
35.0	193	109		
35.5	195	111		
36.0	196	112		
36.5	198	114		
37.0	206	116		
37.5	208	118		
38.0	209	119		
38.5	211	121	40	WCMX 080412
39.0	222	122		
39.5	224	124		
40.0	225	125		
41.0	228	128		
42.0	231	131		
43.0	234	134		
44.0	237	137		
45.0	240	140		
46.0	243	143		
47.0	246	146		
48.0	249	149		
49.0	252	152		
50.0	255	155		
51.0	258	158		
52.0	261	161		
53.0	264	164		
54.0	267	167		
55.0	270	170		
56.0	278	176		
57.0	281	179		
58.0	284	182		
59.0	287	185		
60.0	290	188		
-				

3DSP

3xD SP Type Indexable Drill

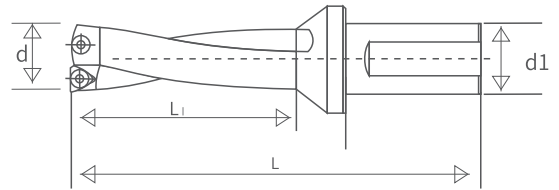

How to Order: 3DSP+ Size

Unit: mm

Size(d)	L	L1	d1 (h6)
16.0	122	51	20/25
16.5	124	53	
17.0	125	54	
17.5	127	56	
18.0	128	57	
18.5	130	59	
19.0	131	60	25
19.5	133	62	
20.0	134	63	
20.5	136	65	
21.0	137	66	
21.5	139	68	
22.0	140	69	
22.5	142	71	
23.0	146	72	
23.5	148	74	
24.0	149	75	
24.5	151	77	
25.0	152	78	32
25.5	160	80	
26.0	161	81	
26.5	163	83	
27.0	164	84	
27.5	166	86	
28.0	167	87	
28.5	169	89	
29.0	172	91	
29.5	174	93	
30.0	178	94	
30.5	180	96	
31.0	181	97	
31.5	183	99	
32.0	184	100	
32.5	186	102	
33.0	187	103	

Size(d)	L	L1	d1 (h6)
33.5	189	105	32
34.0	190	106	
34.5	192	108	
35.0	193	109	
35.5	195	111	
36.0	196	112	
36.5	198	114	
37.0	206	116	
37.5	208	118	
38.0	209	119	
38.5	211	121	
39.0	222	122	
39.5	224	124	
40.0	225	125	
41.0	228	128	
42.0	231	131	
43.0	234	134	
44.0	237	137	
45.0	240	140	
46.0	243	143	
47.0	246	146	
48.0	249	149	
49.0	252	152	
50.0	255	155	
51.0	258	158	
52.0	261	161	
53.0	264	164	
54.0	267	167	
55.0	270	170	
56.0	278	176	
57.0	281	179	
58.0	284	182	
59.0	287	185	
60.0	290	188	
-			40

4DWC

4xD WC Type Indexable Drill

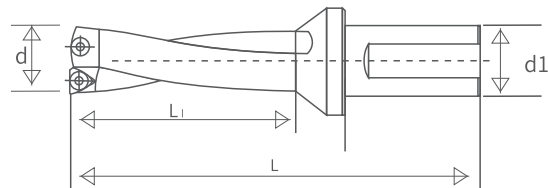

How to Order: 4DWC+ Size

Unit: mm

Size(d)	L	L1	d1 (h6)	Suitable Insert
16.0	138	67	20/25	WCMX 030208
16.5	140	69		
17.0	142	71		
17.5	144	73		
18.0	146	75		
18.5	148	77		
19.0	150	79		
19.5	152	81		
20.0	154	83		
20.5	156	85		
21.0	158	87	25	WCMX 040208
21.5	160	89		
22.0	162	91		
22.5	164	93		
23.0	169	95		
23.5	171	97		
24.0	173	99		
24.5	175	101		
25.0	177	103		
25.5	185	105		
26.0	187	107		
26.5	189	109		
27.0	191	111		
27.5	193	113		
28.0	195	115		
28.5	197	117		
29.0	201	120		
29.5	203	122		
30.0	208	124	32	WCMX 06T308
30.5	210	126		
31.0	212	128		
31.5	214	130		
32.0	216	132		
32.5	218	134		
33.0	220	136		

Size(d)	L	L1	d1 (h6)	Suitable Insert
33.5	222	138	32	WCMX 06T308
34.0	224	140		
34.5	226	142		
35.0	228	144		
35.5	230	146		
36.0	232	148		
36.5	236	150		
37.0	243	153		
37.5	245	155		
38.0	247	157		
38.5	249	159		
39.0	261	161		
39.5	263	163		
40.0	265	165		
41.0	269	169		
42.0	273	173		
43.0	277	177		
44.0	281	181		
45.0	285	185	-	=
46.0	289	189		
47.0	293	193		
48.0	297	197		
49.0	301	201		
50.0	305	205		
51.0	309	209		
52.0	313	213		
53.0	317	217		
54.0	321	221		
55.0	325	225		
56.0	334	232		
57.0	338	236		
58.0	342	240		
59.0	346	244		
60.0	350	248		
-	-	=		

4DSP

4xD SP Type Indexable Drill

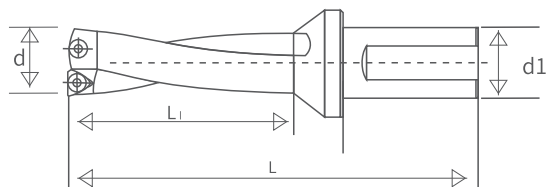

How to Order: 4DSP+ Size

Unit: mm

Size(d)	L	L1	d1 (h6)
16.0	138	67	20/25
16.5	140	69	
17.0	142	71	
17.5	144	73	
18.0	146	75	
18.5	148	77	
19.0	150	79	25
19.5	152	81	
20.0	154	83	
20.5	156	85	
21.0	158	87	
21.5	160	89	
22.0	162	91	
22.5	164	93	
23.0	169	95	
23.5	171	97	
24.0	173	99	
24.5	175	101	
25.0	177	103	32
25.5	185	105	
26.0	187	107	
26.5	189	109	
27.0	191	111	
27.5	193	113	
28.0	195	115	
28.5	197	117	
29.0	201	120	
29.5	203	122	
30.0	208	124	
30.5	210	126	
31.0	212	128	
31.5	214	130	
32.0	216	132	
32.5	218	134	
33.0	220	136	

Size(d)	L	L1	d1 (h6)	
33.5	222	138	32	
34.0	224	140		
34.5	226	142		
35.0	228	144		
35.5	230	146		
36.0	232	148		
36.5	236	150		
37.0	243	153		
37.5	245	155		
38.0	247	157		
38.5	249	159		
39.0	261	161		40
39.5	263	163		
40.0	265	165		
41.0	269	169		
42.0	273	173		
43.0	277	177		
44.0	281	181		
45.0	285	185		
46.0	289	189		
47.0	293	193		
48.0	297	197		
49.0	301	201		
50.0	305	205		
51.0	309	209		
52.0	313	213		
53.0	317	217		
54.0	321	221		
55.0	325	225		
56.0	334	232		
57.0	338	236		
58.0	342	240		
59.0	346	244		
60.0	350	248		

5DWC

5xD WC Type Indexable Drill

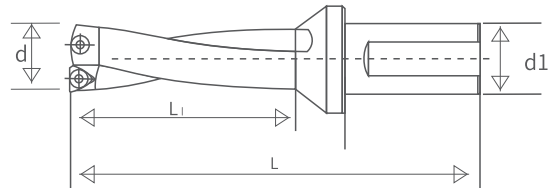

How to Order: 5DWC+ Size

Unit: mm

Size(d)	L	L1	d1 (h6)	Suitable Insert
20.0	174	103	25	WCMX 030208
20.5	177	106		
21.0	179	108		
21.5	182	111		
22.0	184	113		
22.5	187	116		
23.0	192	118		
23.5	195	121		
24.0	197	123		
24.5	200	126		
25.0	202	128		
25.5	210	131		
26.0	213	133		
26.5	216	136		
27.0	218	138		
27.5	221	141		
28.0	223	143		
28.5	226	146		
29.0	230	149		
29.5	233	151		
30.0	238	154		
30.5	241	157		
31.0	243	159		
31.5	246	162		
32.0	248	164		
32.5	251	167		
33.0	253	169		
33.5	256	172		
34.0	258	174		
34.5	261	177		
35.0	263	179		
35.5	265	182		
36.0	268	184		
36.5	271	187		
37.0	280	190		

Size(d)	L	L1	d1 (h6)	Suitable Insert
37.5	283	193	32	WCMX 06T308
38.0	285	195		
38.5	288	198		
39.0	300	200		
39.5	303	203		
40.0	305	205		
41.0	310	210		
42.0	315	215		
43.0	320	220		
44.0	325	225		
45.0	330	230		
46.0	335	235		
47.0	340	240		
48.0	345	245		
49.0	350	250		
50.0	355	255		
51.0	360	260		
52.0	365	265		
53.0	370	270		
54.0	375	275		
55.0	380	280		
56.0	385	285		
57.0	390	295		
58.0	395	300		
59.0	400	305		
60.0	405	310		

5DSP

5xD SP Type Indexable Drill

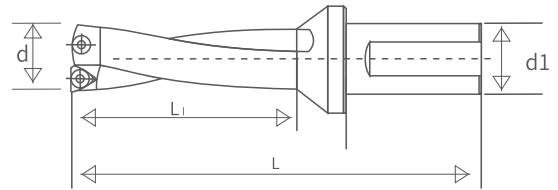

How to Order: 5DSP+ Size

Unit: mm

Size(d)	L	L1	d1 (h6)	
20.0	174	103	25	
20.5	177	106		
21.0	179	108		
21.5	182	111		
22.0	184	113		
22.5	187	116		
23.0	192	118		
23.5	195	121		
24.0	197	123		
24.5	200	126		
25.0	202	128		
25.5	210	131		32
26.0	213	133		
26.5	216	136		
27.0	218	138		
27.5	221	141		
28.0	223	143		
28.5	226	146		
29.0	230	149		
29.5	233	151		
30.0	238	154		
30.5	241	157		
31.0	243	159		
31.5	246	162		
32.0	248	164		
32.5	251	167		
33.0	253	169		
33.5	256	172		
34.0	258	174		
34.5	261	177		
35.0	263	179		
35.5	265	182		
36.0	268	184		
36.5	271	187		
37.0	280	190		

Size(d)	L	L1	d1 (h6)
37.5	283	193	32
38.0	285	195	
38.5	288	198	
39.0	300	200	
39.5	303	203	
40.0	305	205	
41.0	310	210	40
42.0	315	215	
43.0	320	220	
44.0	325	225	
45.0	330	230	
46.0	335	235	
47.0	340	240	
48.0	345	245	
49.0	350	250	
50.0	355	255	
51.0	360	260	
52.0	365	265	
53.0	370	270	
54.0	375	275	
55.0	380	280	
56.0	385	285	
57.0	390	295	
58.0	395	300	
59.0	400	305	
60.0	405	310	

WCMX

WC type Carbide Insert

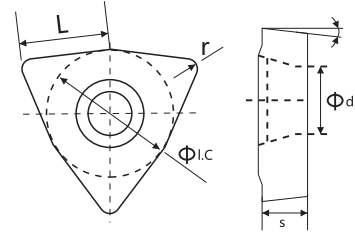

How to Order: WCMX code

Unit: mm

Size	L	l.C	s	d	r	Drill Size
WCMX030204	3.8	5.65	2.38	2.8	0.4	16-20.5
WCMX040208	4.3	6.35	2.38	3.1	0.8	21-25.5
WCMX050308	5.4	7.94	3.18	3.2	0.8	26-30.5
WCMX06T308	6.5	9.525	3.97	3.7	0.8	31-41

2CE

Solid Carbide 2 Flutes Endmill

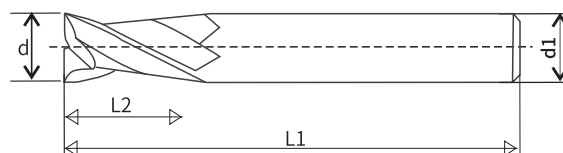

How to Order: 2CE+ Size

Unit: mm

Size(d)	d1	L1	L
1	4	3	50
1.5	4	4	50
2	4	6	50
2.5	4	8	50
3	4	8	50
3.5	4	10	50
4	4	11	50
4.5	6	11	50
5	6	13	50
5.5	6	13	50
6	6	16	50
6.5	8	16	60
7	8	20	60
7.5	8	20	60
8	8	20	60
8.5	10	20	75
9	10	20	75
9.5	10	22	75
10	10	25	75
11	12	30	75
12	12	32	75
14	14	35	80
16	16	40	100
18	18	45	100
20	20	45	100

4CE

Solid Carbide 4 Flutes Endmill

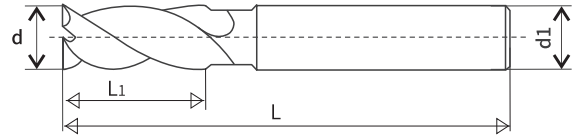
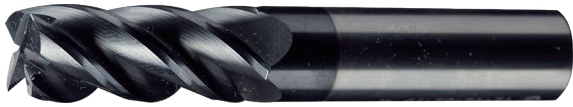

How to Order: 4CE+ Size

Unit: mm

Size(d)	d1	L1	L
1	4	3	50
1.5	4	4	50
2	4	6	50
2.5	4	8	50
3	4	8	50
3.5	4	10	50
4	4	11	50
4.5	6	11	50
5	6	13	50
5.5	6	13	50
6	6	16	50
6.5	8	16	60
7	8	20	60
7.5	8	20	60
8	8	20	60
8.5	10	20	75
9	10	20	75
9.5	10	22	75
10	10	25	75
11	12	30	75
12	12	32	75
14	14	35	80
16	16	40	100
18	18	45	100
20	20	45	100

3CEA

Solid Carbide Endmill 3 Flutes for Aluminum

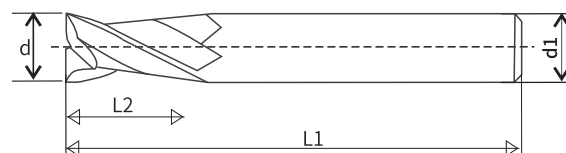

How to Order: 3CEA+ Size

Unit: mm

Size(d)	d1	L1	L
1	6	3	50
1.5	6	5	50
2	6	6	50
2.5	6	8	50
3	6	11	50
4	6	13	50
5	6	17	55
6	6	17	55
7	8	22	65
8	8	22	65
9	10	27	70
10	10	27	70
12	12	32	80
14	14	37	85
16	16	42	100
18	18	48	110
20	20	48	110

4CESS

Solid Carbide 4 Flutes Endmill for Stainless Steel

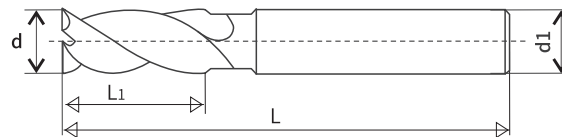

How to Order: 4CESS+ Size

Unit: mm

Size(d)	d1	L1	L
6	6	10	54
8	8	12	58
10	10	14	66
12	12	16	73
14	14	18	75
16	16	22	82
18	18	24	84
20	20	26	92

H2CE

High Hardness Solid Carbide 2 Flutes Endmill

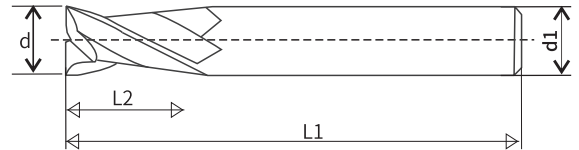

How to Order: H2CE+ Size

Unit: mm

Size(d)	d1	L1	L
1	4	3	50
1.5	4	4	50
2	4	6	50
2.5	4	8	50
3	4	8	50
3.5	4	10	50
4	4	11	50
4.5	6	11	50
5	6	13	50
5.5	6	13	50
6	6	16	50
6.5	8	16	60
7	8	20	60
7.5	8	20	60
8	8	20	60
8.5	10	20	75
9	10	20	75
9.5	10	22	75
10	10	25	75
11	12	30	75
12	12	32	75
14	14	35	80
16	16	40	100
18	18	45	100
20	20	45	100

H4CE

High Hardness Solid Carbide 4 Flutes Endmill

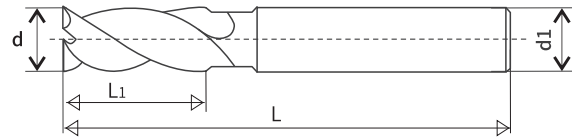
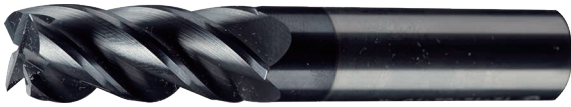

How to Order: H4CE+ Size

Unit: mm

Size(d)	d1	L1	L
1	4	3	50
1.5	4	4	50
2	4	6	50
2.5	4	8	50
3	4	8	50
3.5	4	10	50
4	4	11	50
4.5	6	11	50
5	6	13	50
5.5	6	13	50
6	6	16	50
6.5	8	16	60
7	8	20	60
7.5	8	20	60
8	8	20	60
8.5	10	20	75
9	10	20	75
9.5	10	22	75
10	10	25	75
11	12	30	75
12	12	32	75
14	14	35	80
16	16	40	100
18	18	45	100
20	20	45	100





SINCE 1959

HENAN HEYGO TOOLS CO., LTD

Tel: 0086-373-7876193 / Email: info@heygotools.com / Web: www.heygotools.com

Address: No.8 Dongqiang road, New east technology park, Xinxiang, Henan, China